

FÖRST™

TR8D

Operation & Maintenance Manual

English



Redwood Global Ltd,
Unit 86, Livingstone Road, Walworth Business Park, Andover,
Hampshire. SP10 5NS. United Kingdom

Contents

1.0 Introduction.....	5
1.1 Purpose of Chipper.....	6
1.2 Exterior Components.....	7
2.0 Safety.....	9
2.1 Safety Working.....	9
2.2 DO's and DON'Ts.....	10
2.3 Noise Test Information.....	11
3.0 Transportation & Storage.....	12
3.1 Track control and driving.....	12
3.2 Transporting the Chipper.....	13
3.3 Care of Rubber Tracks.....	13
3.4 Lifting the Chipper.....	14
3.5 Storage of the Chipper.....	14
4.0 Chipper Operation.....	15
4.1 Control Panel & Ignition.....	16
4.1.1 Control Panel.....	16
4.1.2 Ignition Switch.....	17
4.1.3 Control Panel.....	17
4.2 Feed Speed Adjustment.....	19
4.3 Emergency Stopping.....	20
4.4 Feed Jam & Blockages.....	21
5.0 Routine Maintenance.....	22
5.1 Debris Screen.....	23
5.2 Engine Maintenance.....	23
5.3 Fastener tightening torques.....	23
5.4 Service Schedule.....	24
5.5 Chipper Diagrams.....	26
5.5.1 Main Covers.....	26
5.5.2 Side Panel.....	26
5.5.3 Top Feed Roller.....	27
5.5.4 Engine Bay.....	27
5.6 Blade Changing.....	28
5.7 Blade Sharpening.....	29
5.8 Hydraulic Oil Filter.....	30

5.6.1 Removal and Replacement	30
5.9 Oils, Fluids and Lubricants	31
5.10 Drive belt tension	32
5.11 Battery	33
5.11.1 Battery safety information.....	33
5.11.2 Storage and transport.....	33
5.11.3 Initial operation	33
5.11.4 Battery removal & maintenance	33
5.11.5 Charging.....	34
5.11.6 Jump starting	34
5.11.7 Taking battery out of service	35
6.0 Parts Lists & Diagrams	36
6.1 Tray & Stop Bar	36
6.2 Chipping Chamber	37
6.3 Top feed roller assembly	38
6.4 Flywheel Assembly	39
6.5 Bottom Feed Roller	40
6.6 Anvil.....	41
6.7 Stone Trap	42
6.8 Flywheel belt tensioner assembly	43
6.9 Safety Curtain.....	44
6.10 Chute Assembly.....	45
6.11 Fuel tank assembly	46
6.12 Hydraulics circuit diagram	47
6.13 Electrical Circuit Diagrams	48
6.13.1 Touch Sensors.....	48
.....	48
6.13.2 Wiring Harness	48
6.14 Decals	49
6.15 Manufacturer's Statutory Plate	50
7.0 Warranty and Certification	51
7.1 Warranty.....	51
7.1.1 Warranty Statement.....	51
7.1.2 Warranty Claims	51
7.2 Certification	52

1.0 Introduction

Thank you for becoming the owner of this Redwood Global Ltd, Först TR8D wood chipping machine. By observing the contents of this manual, we hope the chipper gives safe and productive service. This user manual is intended for the owner/operator to safely and effectively operate this chipper and carry out routine maintenance between services. This is not a comprehensive service manual. See Service Schedule for routine maintenance and when to take the chipper to a service specialist. For engine maintenance, please refer to the engine manual supplied with this chipper.

This chipper has been through a pre-delivery inspection before leaving the factory and is ready to use.

Before use and as a minimum, the safety and chipper operation sections covered in Chapter 2 be read and understood. Failure to do so could result in serious injury or loss of life to the operator and others nearby.

Also, damage to property and this chipper may occur. Please observe and obey all warning signs (decals) located on the chipper. Their meaning is covered in this manual under decals.

All personnel working with this chipper must be adequately trained in its use and most importantly, follow the advice on safe working practices.

Redwood Global Ltd endeavour to continuously develop and improve its products. They reserve the right to make changes at any time, without notice or incurring any obligation.

Continuous improvement will affect chipper design and production so there may be minor discrepancies between the actual product and this manual.

This manual must remain with the chipper for reference by operators and includes hiring or if the chipper is resold.

1.1 Purpose of Chipper

The Först TR8D is designed to reduce wood material up to 203mm diameter and 254mm wide to woodchip. This chipper is capable of processing up to 5.5 tonnes of wood per hour.

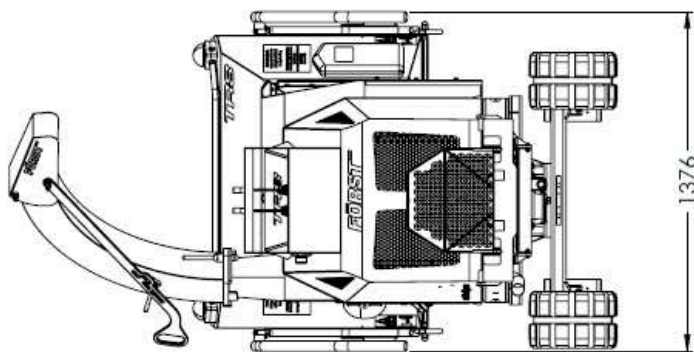
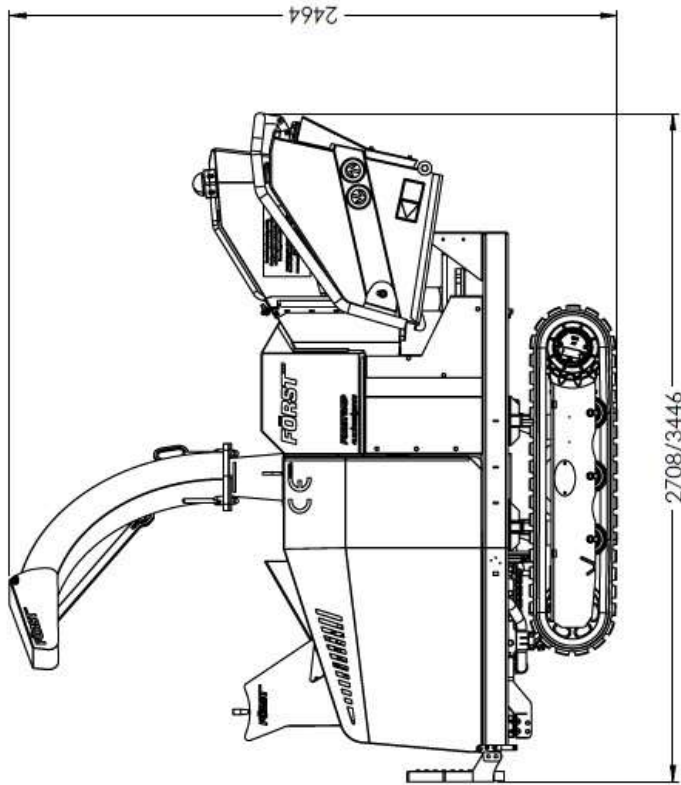

Engine	Doosan D18	Roller Feed	Twin hydraulic motors
Max. power	42kW (56hp)	Max. material diameter	203mm
Cooling	Water Cooled	Fuel Capacity	35 litres
Overall weight	1250kg	Hydraulic Oil Capacity	35 litres
Starting	Electric	Material processing	5.5 tonnes/hour
		Fuel type	Ultra-Low Sulphur Diesel

1.2 Exterior Components

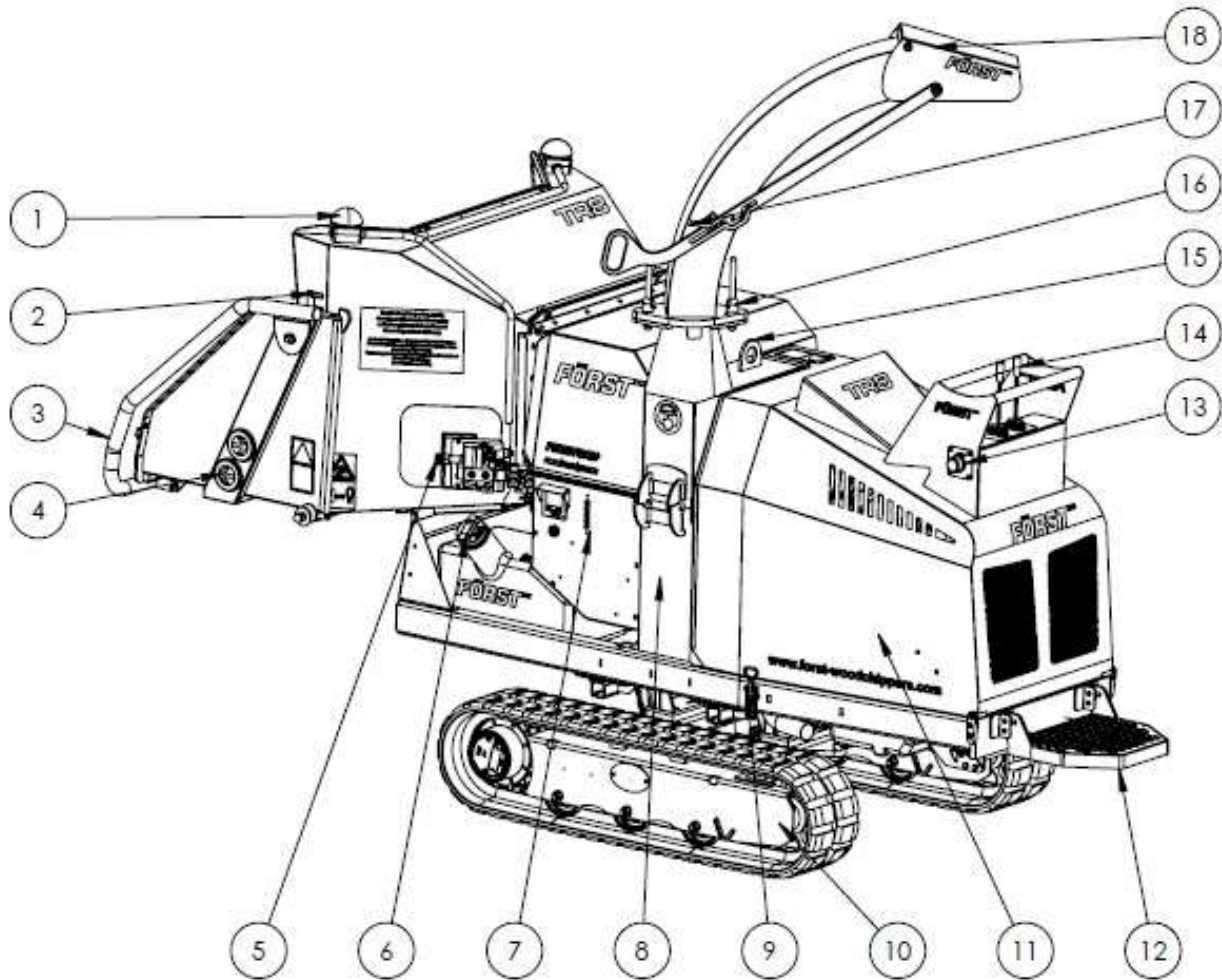

- | | |
|-------------------------------|--------------------------|
| 1. E-Stop | 10. Track base |
| 2. Hopper tray latch | 11. Engine cover |
| 3. Stop bar | 12. Footplate |
| 4. Feed touch sensors | 13. Throttle |
| 5. Control valve speed adjust | 14. Control levers |
| 6. Fuel tank | 15. Lifting point |
| 7. Control panel | 16. Chute rotation clamp |
| 8. Chipping chamber | 17. Chute handle clamp |
| 9. Engine cover latch | 18. Chute hood |

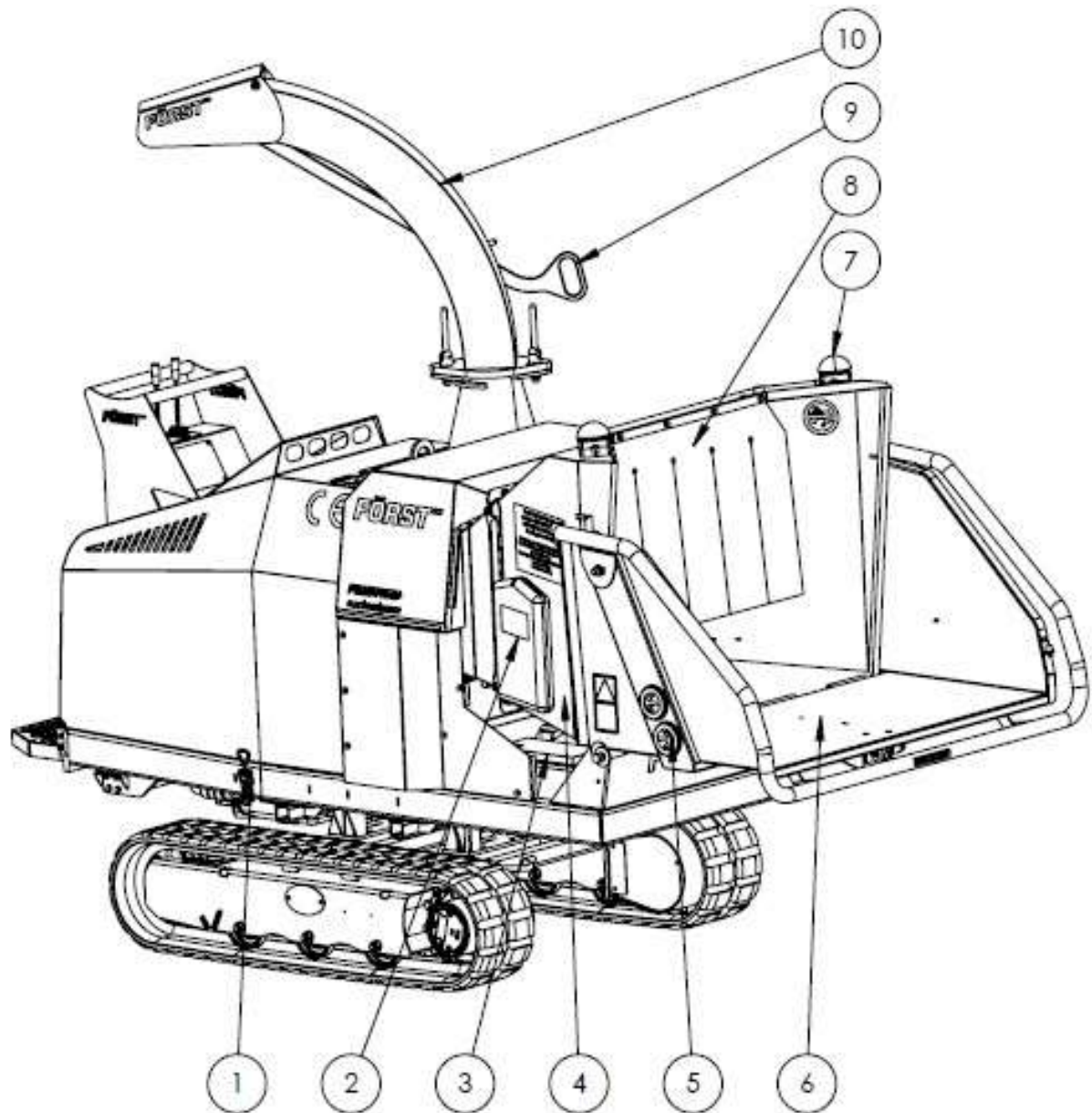

- | | |
|-----------------------|-------------------|
| 1. Engine cover latch | 6. Hopper tray |
| 2. Document holder | 7. E-Stop |
| 3. Battery | 8. Safety curtain |
| 4. Removable hopper | 9. Chute handle |
| 5. Feed touch sensors | 10. Chute |

2.0 Safety

2.1 Safety Working

Before using this chipper, make sure that you are trained and fluent in its operation. Know the location of and how to use all the safety features. Know how to control the feed and stop the chipper in an emergency. Be familiar with the hazards and safe working practices to prevent injury and damage to property and chipper. Also be aware of the legal restrictions for personnel and towing with vehicles.

- The minimum age for service personnel is 18 years. Personnel aged 16 can use the chipper for training under supervision by a suitably trained person of 18 years or over.
- Operators and personnel working with this chipper must not be under the influence of alcohol, drugs or medication that would impair judgement, concentration or reaction times. Excessive tiredness is also a risk.
- In use, woodchip and debris are ejected with considerable force from the chute and can travel up to 10m. Make sure the chute directs woodchip to a safe location so that no one can be harmed or property damaged. Do not allow discharge to be directed onto roads or public rights of way.
- Maintain a 10m exclusion zone around the chipper and clearly mark if in a public area. Keep this area free of material build up.
- Make sure the chipper is on even, level and stable ground and cannot move or topple when in use. Use wheel chocks if necessary.
- Keep children and animals well away from the working area.
- The chipper operator must wear protective equipment:
 - Chainsaw safety helmet (EN 397) with mesh visor (EN 1731)
 - Correctly rated ear defenders (EN 352)
 - Work gloves with elasticated wrist bands.
 - Steel toe cap boots (EN345-1)
 - Close fitting heavy duty non-slag clothing. Hi-viz clothing (EN 471) if needed.
 - Protect breathing with a face mask if appropriate. Some plant material can give off harmful dust and poisonous vapours. This may cause respiratory problems or serious poisoning. Check the material to be processed before starting.
- **DO NOT** wear rings, bracelets, watches, jewellery or anything that could be caught on the material being fed and draw you into the chipper.
- All personnel operating or feeding material into the chipper must wear heavy duty non-slag clothing to help prevent being caught on material and drawn into the chipper. The feed mechanism of this chipper uses high powered hydraulic motors to drive sharp toothed rollers that feed material into the cutting blades. **DO NOT** take risks with it. **NEVER ASSIST ANY MATERIAL INTO THE FEED ROLLERS WITH HANDS OR FEET.** Use the wooden paddle or further long material if necessary.
- Never climb onto the hopper area while the chipper is in operation.
- **CAUTION!** – Keep hands and feet outside the hopper. Do not attempt to force material into the chipper by hand – use a piece of wood if necessary.
- Material can be forcibly ejected from the hopper towards the operator. Ensure full head and face protection is worn.
- Very twisted material should be trimmed into manageable pieces. Failure to do this can result in material extending outside the hopper, moving aggressively side-to-side creating a hazard to the operator.
- Do not try to force material over 150mm in diameter into the chipper.
- Carefully site the chipper so operators can work furthest from any local danger. For example, on a road side, place chipper so operators work on the verge and not in the road exposed to traffic

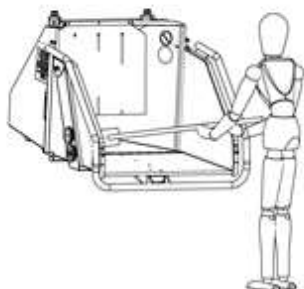

2.2 DO's and DON'Ts

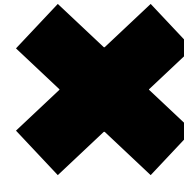

- **DO** ensure that the starting of the chipper can cause no hazard before starting. i.e. no persons are in the hopper or in any other danger area
- **DO** stop the chipper before making any adjustments, refuelling or cleaning
- **DO** make sure the chipper has stopped rotating and remove the ignition key before any maintenance or the chipper is left unattended. The belts and pulley are to be used to ensure visually that the chipper has stopped rotating
- **DO** ensure that the chipper is level, well supported and cannot move during use
- **DO** run the chipper at full throttle
- **DO** conduct regular chipper checks for visual fluid leaks
- **DO** take regular breaks. Wearing protective equipment can be hot and tiring leading to a lack of concentration, increasing the risk of having an accident
- **DO** keep hands, feet and clothing out of feed area, chute and moving parts
- **DO** always check the **all** of controls and safety devices (emergency stops, stop bar) **before** feeding any wood into the chipper
- **DO** remove any additional debris attached to the wood before commencing work i.e. nails, wire, rope etc

- **DO NOT** use chipper in poor visibility or insufficient light to see clearly
- **DO NOT** use or attempt to start the chipper without the discharge chute or guards correctly and securely fitted
- **DO NOT** stand directly in front of the in-feed hopper when using the chipper. Stand to one side
- **DO NOT** allow the following to enter the chipper as damage is likely:

Bricks	Metal
String	Glass
Cloth	Rubber
Plastic	Roots
Stones	Bedding Plants

- **DO NOT** stand in front of the chute
- **DO NOT** smoke when refuelling. Petrol fuel is highly flammable and explosive in certain conditions
- **DO NOT** let anyone who has not received instruction, operate the chipper
- **DO NOT** climb on the chipper at any time except for a tracked chipper ride-on plate where fitted
- **DO NOT** handle material partially engaged in the chipper while in operation
- **DO NOT** touch any exposed wiring whilst the chipper is running
- **DO NOT** restart the chipper immediately if an emergency stop has caused a shut down. Before disengaging the emergency stop a thorough inspection of the chipper should be carried out to ensure the safety conditions are being met

2.3 Noise Test Information

Chipper
Test

TR8D 55
50mm x 50mm 4.2m long sawn pine

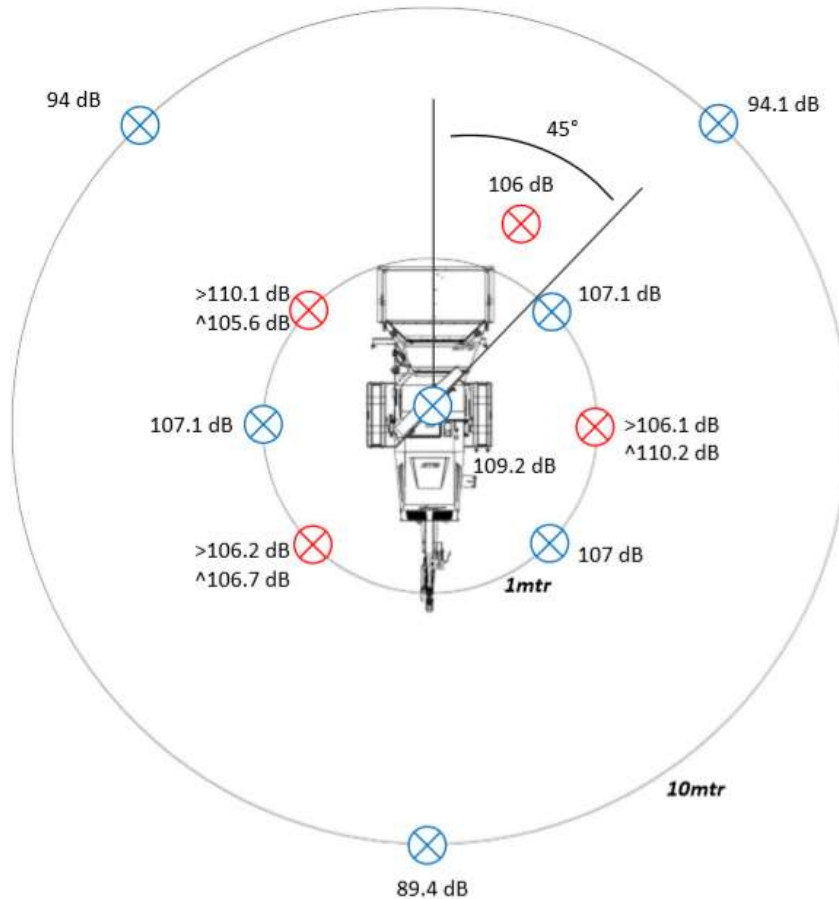

Noise levels above 85dB (A) will be experienced at the working position and within a 4-metre radius. Operators and personnel within a 4-metre radius must wear appropriate ear protection at all times while chipper is in operation to prevent the risk of hearing damage.

A-weighted emission sound pressure (beside operator's ear) $L_{pA} = 107.1\text{dB(A)}$.
Peak C-weighted instantaneous sound pressure (beside operator's ear) $LC_{peak} = 123.3\text{dB(C)}$. Results at 10 metre radii are calculated.

Guaranteed sound power level: 121dB(A)

As required by Forestry machinery - Wood chippers – Safety BS EN 13525 and in line with Machinery Directive 2006/42/EC.

3.0 Transportation & Storage

3.1 Track control and driving

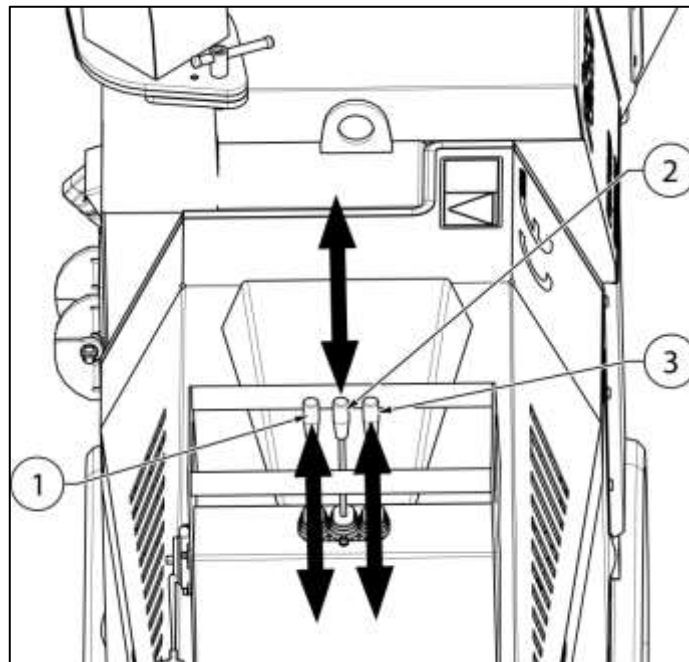

1. Left track forward & reverse
2. Varitrack (optional):
 - Forward – tracks out
 - Backward – tracks in
3. Right track forward & reverse

Driving controls are all situated on the engine cover and operated while at the machine front or standing on the fold down foot plate.

The two outer levers control track rotation direction and speed. When used equally together, this gives forward and reverse and speed increase with greater lever movement. Steering is by using the levers in differing proportions, in opposition or each on their own. Both levers used in extreme opposition will cause the machine to spin on its axis.

Avoid driving on ground too soft to support the machine's weight.

Take great care when driving on inclined ground as there is a risk of the machine toppling. This is most likely when turning or crossing the incline, try to avoid these manoeuvres. Do not drive on ground with an incline in excess of 20°.

Make sure the engine and hydraulic oil are warm before working on inclined ground. If the machine has to be stopped on an incline, make sure that the machine is pointing either up or down the slope. Also chock both tracks at the downhill end.

3.2 Transporting the Chipper

- Always carryout loading to and unloading from the transporting vehicle on solid level ground.
- Use a loading ramp of less than 15° that is strong and wide enough to take the machine's weight.
- Make sure the ramp and transporting vehicle bed are clean and free of mud, ice or oil. If slippery, this presents a danger.
- In cold weather, make sure the engine and hydraulic oil are warm before loading/unloading.
- Do not steer the machine while on ramps, this is extremely dangerous. If adjustment has to be made, drive back onto ground or vehicle bed, steer, then negotiate the ramps.
- Drive slowly while loading/unloading and take care when the machine passes over hump at the ramp to bed join.
- Position the machine at the trailer/vehicle bed centre.
- Fasten machine securely to transport vehicle via both lashing eyes on track base front and rear. Use appropriately rated cables, chains or ratchet straps. Make sure that no securing passes over or traps any hydraulic hoses.
- Clear machine of loose woodchip material before departing.
- Ensure the chute is securely fixed at the inboard position before departing.
- Ensure that the hopper tray is closed in the up position and the locking latch is fully engaged before departing.

3.3 Care of Rubber Tracks

- Do not manoeuvre on hard, stony and highly abrasive surfaces.
- Do not leave tracks exposed to direct sunlight for more than 3 months.
- Avoid aggressive steering on asphalt and concrete as this will cause excessive track wear. Also avoid driving on asphalt that is hot and above 60°C, it will damage the tracks and asphalt.
- Loose tracks can be detached and damaged when manoeuvring on very uneven ground.
- Tracks are for use on soft ground. They will rapidly deteriorate if used on hard or abrasive surfaces such as sand, stone or minerals.
- Do not let synthetic oils or fuel get onto the track. Clean immediately if this occurs.
- Do not use tracks in a marine or coastal environment as salt and salt air will corrode the steel inner core and track components.

3.4 Lifting the Chipper

The lifting eye is designed for securely holding the chipper's weight only. Do not use hoist hook directly on the lifting eye. Use a correctly rated safety shackle. Inspect lifting eye before each use and do not use if damaged.

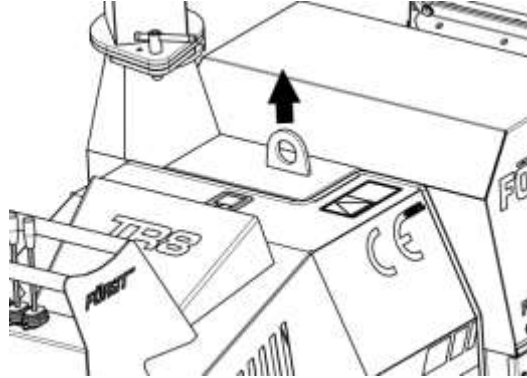

3.5 Storage of the Chipper

For safe storage of the chipper, ensure the following points are met:

1. Chipper to be stored on a level, uneven surface
2. Hopper tray to be in the 'Up' Position

4.0 Chipper Operation

1. Fold down hopper tray
2. Start engine
 - a. Turn ignition key to pre-heat
 - b. Wait for display to indicate 'start engine'
 - c. Turn key to crank engine and release once firing
3. Allow engine to run for 30 seconds at idle, then increase revs to full
4. To feed material into chipper, tap the green button once
5. To stop, push the E-Stop button or push the red stop bar
6. To reverse the feed:
 - a. Tap the orange button once for a momentary reverse
 - b. Tap the orange button twice for continuous reverse
7. Stop the machine:
 - a. Touch the E-stop or push the stop bar
 - b. Reduce revs to idle
 - c. Switch off ignition and remove key
8. Before transporting the machine:
 - a. Sweep out debris from hopper
 - b. Close hopper tray using the stop bar and engage the locking pins

4.1 Control Panel & Ignition

This chipper is fitted with an engine PLC (Programmable Logic Controller) system that manages the engine, feed and all safety features. The control panel is located on the right-side panel. Feed and engine speed are controlled with a “No Stress” function ensuring that cutting conditions are kept within optimum limits. This maximises throughput while minimising jams and blockages. There will be times when material is being cut and the feed will momentarily stop until engine speed increases. At this point, the feed will start without warning. Service warnings shown below will be displayed at certain intervals. The engine will not start until OK is pressed.

- First 20 Hour Warning: "Change Hydraulic Oil Filter"
- Every 20 Hour Warning: "Blade and Machine check required see manual"
- 50 Hour Service Warning: "1st Full Service recommended"
- Every 200 Hour Service Warning: "Full Service recommended"

4.1.1 Control Panel

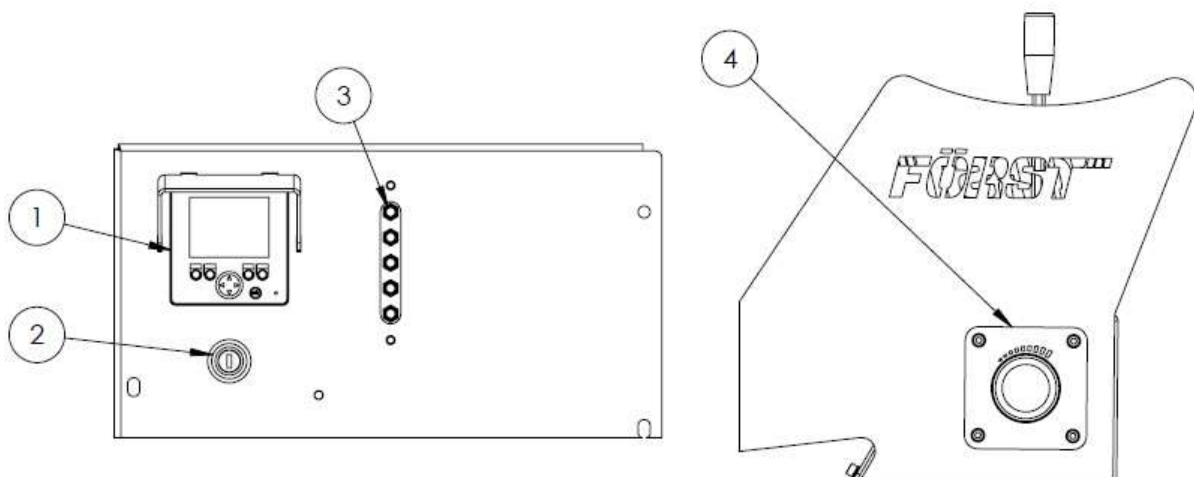

1. Control Panel
2. Ignition

3. Grease bank
4. Throttle

4.1.2 Ignition Switch

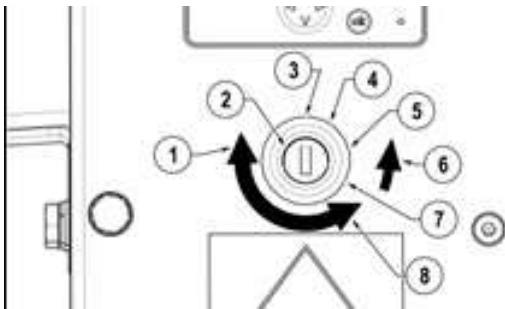

1. Key rotation in switch to start
2. Ignition switch positions & function
3. Off
4. Ignition
5. Pre-Heat
6. Spring biased to pre-heat when released
7. Start
8. Key rotation in switch to stop

Turn ignition key clockwise to first position, then to pre-heat, start display will show, enables pre-heat automatically showing start display + pre-heat.

4.1.3 Control Panel



OR with Pre-heat



Turn ignition key fully clockwise to crank engine. Display will automatically go to P1



If engine fails to start, turn key to off position and start process again. P1 shows Working Hours and charging indicator text at the screen bottom centre.

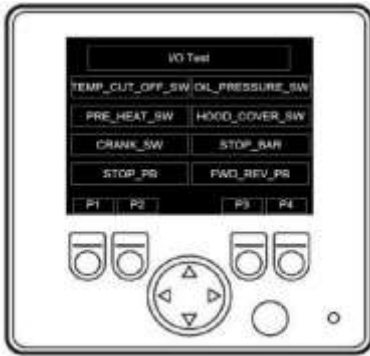

P2 shows I/O tests. Tests all functions and safety controls.

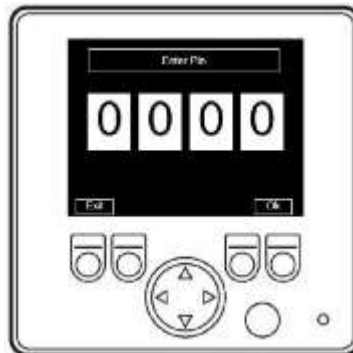

Pin screen

P3 shows No-Stress Settings

- Actual RPM
- Upper Band - 1400 RPM
- Mid Band – 1125 RPM
- Lower Band – 925 RPM
-

Pin screen automatically displays if any setting changes are attempted.



To stop engine, turn off with ignition key by turning fully anti-clockwise.

P4 shows Pre-Heat Settings

- Enable Pre-Heat – True
- Pre-Heat Time – 10
- Crank Time – 3

4.2 Feed Speed Adjustment

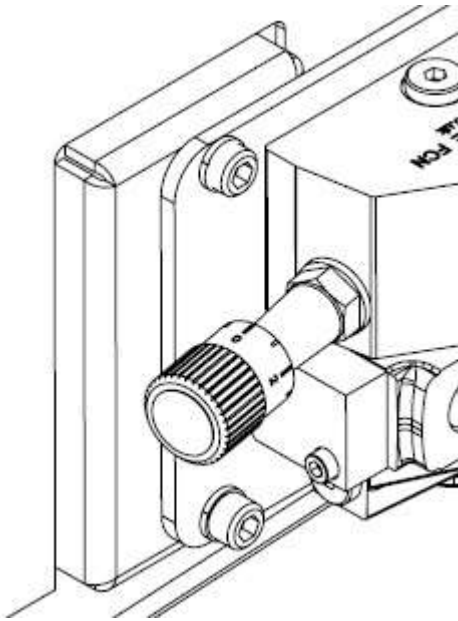

Control valve speed adjustment
Position indicated by pip

0 = minimum

10 = maximum

The feed speed can be adjusted to suit the material being chipped. Turn dial to align number with pip. Set feed speed so that the No-Stress operates as little as possible, this will give the highest throughput. When feeding Leylandii or leafy material, set feed roller speed to 4.5.

4.3 Emergency Stopping

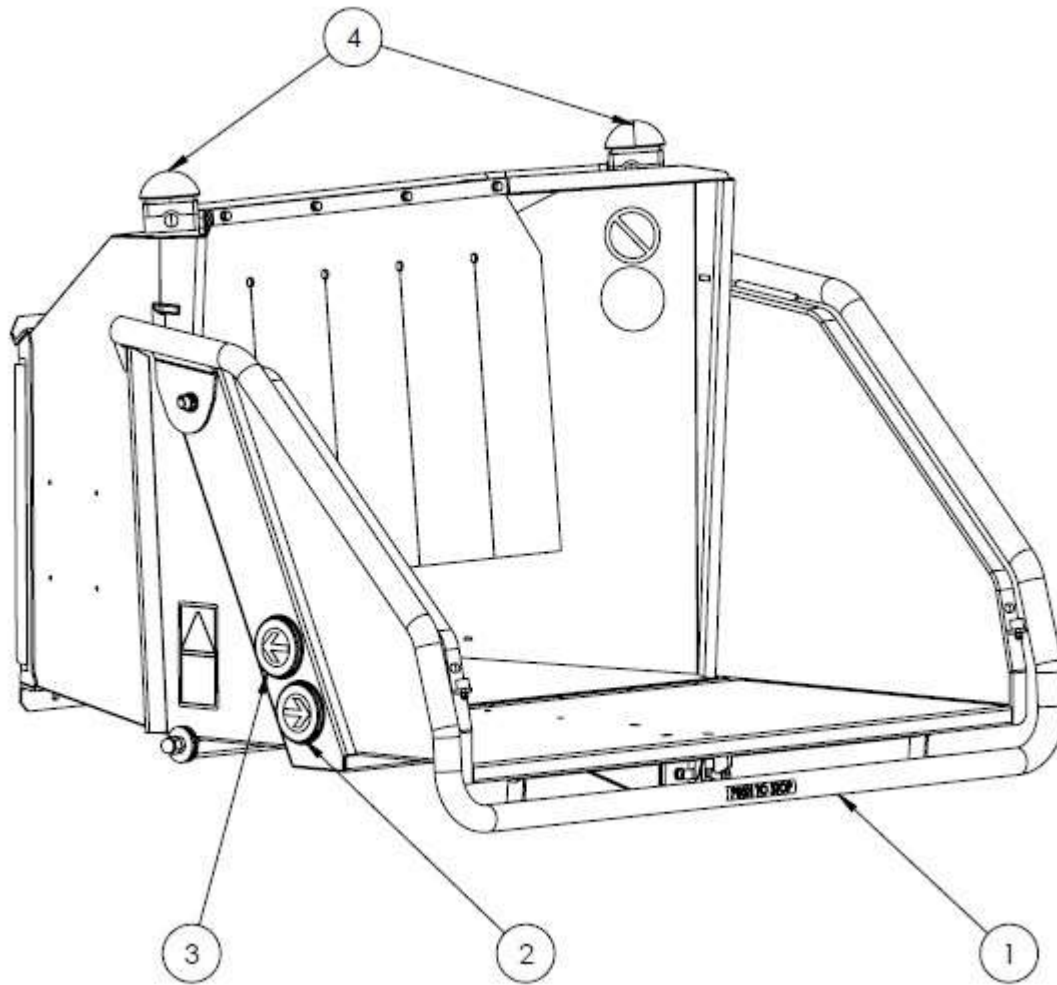

1. Red Stop Bar
2. Orange reverse button
3. Green forward button
4. E-Stop

Before using the chipper:

1. Start the machine with the ignition key on the control panel.
2. With the engine running at full speed tap the green button (3) and the rollers will go into forward (chipping mode).
3. Tap the orange button and the rollers will go into a short reverse, tap it again and the rollers will continue in reverse.
4. To stop the feed rollers, push the red stop bar (1) and the rollers will stop instantly and or push the e-stop button and whole machine will shut down.
5. If any of these functions fail, turn off the machine and remove the key from the ignition switch and contact Redwood Global and ask for service.

4.4 Feed Jam & Blockages

Be aware that whatever is fed into the machine has to come out of the chute. Always monitor the state of chip flow out of the chute. If it stops, **STOP FEEDING MATERIAL IMMEDIATELY**. Continuing to feed material will further compact a blockage and make it more difficult to clear.

If the chipping chamber or chute become blocked:

1. Stop the engine and remove ignition key
2. Remove chute and check that it is clear
3. If the chipping chamber is blocked, open the engine cover, then chipping chamber cover. **DO NOT REACH INTO THE CHIPPING CHAMBER WITH HANDS**. Beware that the flywheel within the chipping chamber has two sharp blades mounted on it and can move causing a serious injury risk. Wearing protective gloves and using a piece of wood, carefully clean out the chipping chamber

If feed becomes jammed:

1. Stop the engine and remove ignition key
2. Open engine and chipping chamber covers
3. Release feed roller spring tension on both sides by slackening off the eye bolt nuts and remove if necessary
4. Insert feed lift tool and lift top feed roller to fully open
5. Insert M12 screw into side of feed chamber and screw completely in. If possible, lower top feed roller onto the screw to secure in the open position. This screw acts as a safety stop once the obstruction has been removed.
6. There should now be access to the feed chamber. Beware that this is the machines cutting zone. The top and bottom feed rollers have sharp teeth and the flywheel cutting blades are not far from them. **DO NOT PUT HANDS INTO THIS AREA**. Wearing protective gloves and using a piece of wood, carefully clear jammed material inside feed chamber
7. When clear, lift top feed roller via lifting tool, remove top feed M12 securing screw, lower top feed roller and remove lifting tool
8. Re-assemble feed tensioner springs and close covers

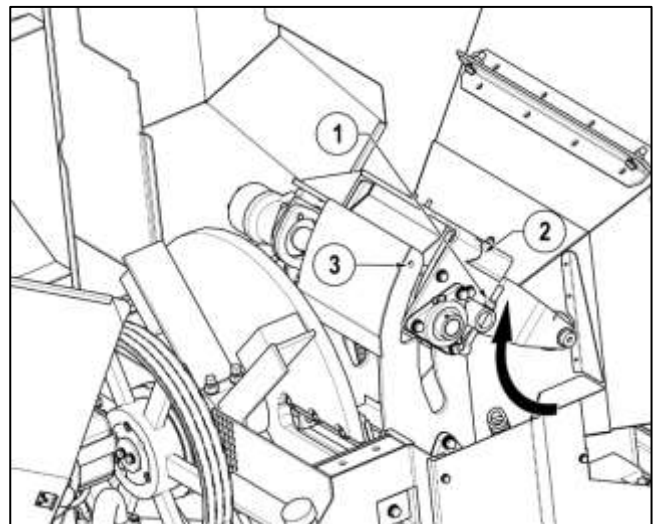

1. Slacken or remove spring tensioner nuts both sides before lifting feed roller
2. Insert top feed roller lifting tool into slot and lift
3. Insert m12 screw to hold feed in open position

5.0 Routine Maintenance

The following must be checked at least on a daily basis during use (also see Service schedule):

- Check engine oil
- Check water level in radiator
- Check debris screen on front of radiator and remove any debris
- Check hydraulic oil level. When the machine is new, the oil level may drop during initial use. Regularly check and top-up until level settles. If a top up is required, thoroughly clean around filler cap before removing to help prevent debris falling into oil tank, top up as required and replace filler cap
- Grease machine. Every 8 hours, one pump of grease to each of the six nipples at the central grease point manifold located near the control panel
- Check all fasteners are present and assembled to the correct torque
- Check proximity sensors on engine cover, removable hopper and trip bar are not damaged and working correctly. The trip bar sensor is the most vulnerable and if severely damaged could result in the trip bar not working
- Check drive belt tension and adjust as necessary
- Check pulleys and taper lock on flywheel shaft
- Check flywheel blades for damage and sharpness. Machine performance is adversely affected if blades are blunt or damaged. Replace and sharpen blades as required. Make sure that the blade seat is clean and free of damage before reassembly. Shims are available to adjust for blade size reduction after sharpening. Please refer to blade sharpening for size limits, adjustment shims and setting. Ensure blade fasteners are correctly installed and tightened to the appropriate torque. Check after 1 hours' work then weekly
- Anvil and side anvil are replaceable and double sided. Make sure that the anvil seat is clean and free of damage before reassembly
- Exercise extreme care to avoid injury when removing and replacing blades and anvils. The flywheel can turn creating crush and cutting points in and around the chipping chamber
- Check all hydraulic hoses and fittings after 5 hours' work. Beware of hydraulic oil leaks, they can cause serious injury while the engine is running and the system is under pressure. A leak can easily inject high pressure oil deep into flesh and blood stream requiring immediate medical attention. **DO NOT CHECK FOR LEAKS WHILE THE ENGINE IS RUNNING.** Hoses to the feed roller hydraulic motors are the most likely to become damaged as they are constantly moving during use. If hoses are replaced, all seals must be replaced at the same time. All replacement hoses must be rated to the pressure of the chipper hydraulic system
- Check top and bottom feed motor bracket bolts weekly

5.1 Debris Screen

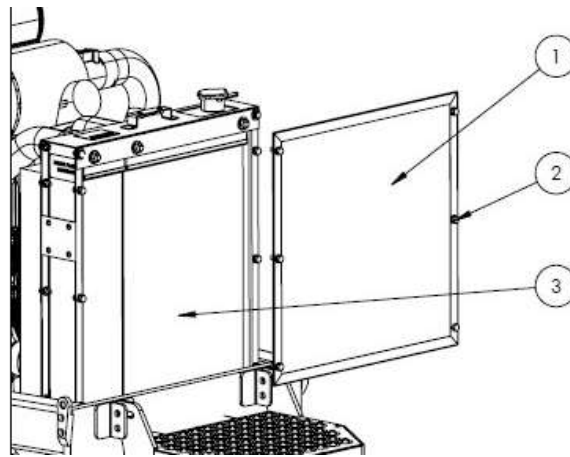

1. Remove the 6 x M8 nuts & bolts and remove the screen
2. Brush off any debris from both sides of the screen
3. Brush off any debris from the radiator
4. Replace screen with 6 x M8 nuts & bolts

5.2 Engine Maintenance

Please refer to the engine manual supplied with this machine for the following:

- Checking the engine oil.
- Changing the engine oil, oil filter and fuel filter.

5.3 Fastener tightening torques

Tightening Torques for class 8.8 and 10.9 fasteners				
	Class 8.8		Class 10.9	
	Nominal Torque (Nm)	Max/Min torque (Nm)	Nominal Torque (Nm)	Max/Min torque (Nm)
M6	10	9.5/10.4	14.5	14/15.3
M8	25	23.1/25.3	35	34/37.2
M10	49	46/51	72	68/75
M12	86	80/87	125	117/128
M16	210	194/214	310	285/314
M20	410	392/431	610	558/615
M24	710	675/743	1050	961/1059

All machine fastener torques should be regularly checked to the above table. In particular, those for the flywheel blades, flywheel bearings, axle assembly, hitch, road wheels and engine mounts.

5.4 Service Schedule

Engine	Chipper	After first 5 Hrs	Every 8 Hrs (Daily)	After first 10 Hrs	After first 20 Hrs	Every 20 Hrs	After first 50 Hrs	Every 50 Hrs / weekly	Every 100 Hrs / 2 weeks	Every 200 Hrs / monthly
	Tighten hydraulic fittings	•								
Check engine oil level & top up if necessary	Check fasteners		•							
	Visual check for fluid leaks		•							
	Check drive belts		•							
	Grease via central point on control panel		•							
	Change hydraulic filter cartridge				•					
	Check brake adjustment (wheeled only)					•				
	Check flywheel shaft bearings					•				
	Check cutting blade & anvil condition, change if required					•				
Check fuel hoses and clamp bands	Check feed roller tension springs & replace if required							•		
	Check wear mark on towing hitch (wheeled only)							•		
Clean air filter element									•	
Clean fuel filter									•	
Check battery electrolyte level									•	
Check fan belt tension	Re-sharpen feed rollers as required								•	
Check radiator hoses & clamp bands										•
Replace oil filter	Check feed roller bearings on motor side, rotate 180 deg									•
Check air intake hose										•

Service Schedule continued

Engine	Chipper	Every 250 Hrs / month	Every 400 Hrs	Every 500 Hrs	Every 800 Hrs	Every 1000 Hrs	Every 1500 Hrs	Every 3000 Hrs	Every 12 months	Every 2 years	Every 5 years
Check & recharge battery		•									
Replace fuel filter cartridge	Change feed roller bearings on motor side		•								
Clean out fuel tank				•							
Clean radiator				•							
Replace engine fan belt				•							
Check & recharge battery	Change hydraulic filter cartridge			•							
Check valve clearances					•						
Change oil & filter	Change hydraulic oil					•					
Check fuel injector pressure							•				
Check fuel injection pump								•			
Check fuel injection timer								•			
Change oil & filter	Get the machine overhauled by a service specialist								•		
Change air filter element									•		
Check wiring for damage & loose connections									•		
Change radiator coolant										•	
Replace battery										•	
Replace radiator hoses & clamp bands										•	
Replace fuel hoses & clamp bands										•	
Change air intake hose										•	
	Change hydraulic hoses										•

5.5 Chipper Diagrams

5.5.1 Main Covers

- Opening sequence: 'A' then 'B' then 'C'

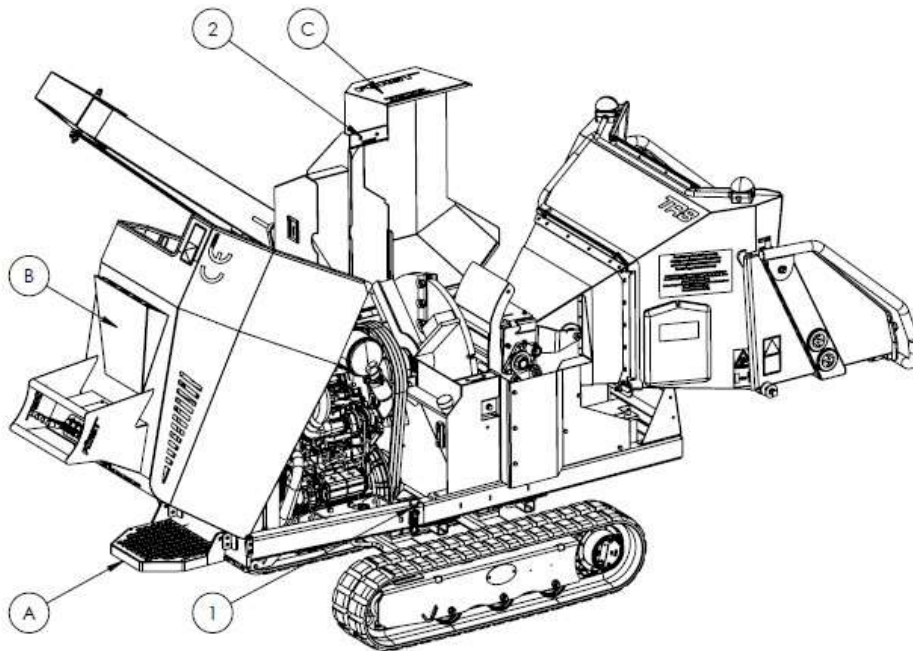

1. Engine cover latch (x2)
2. Chipping chamber cover bolts (x2 M12)

5.5.2 Side Panel

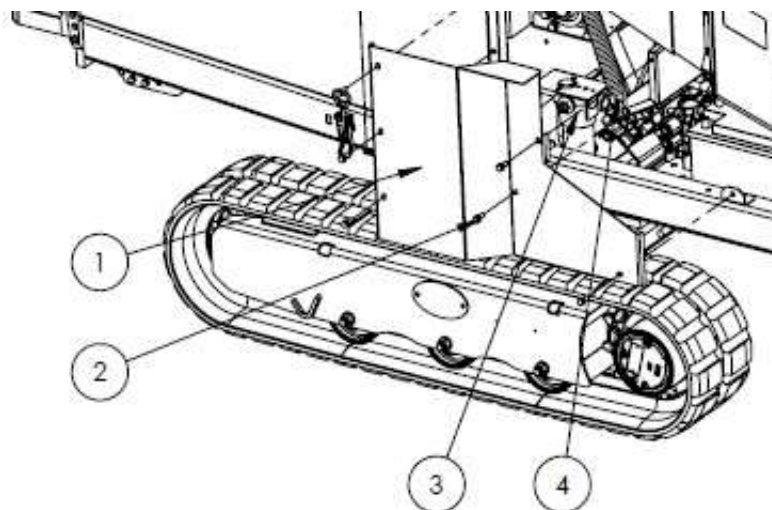

1. Side panel
2. 6 x Fasteners
3. Hydraulic oil filter
4. Tensioner

5.5.3 Top Feed Roller

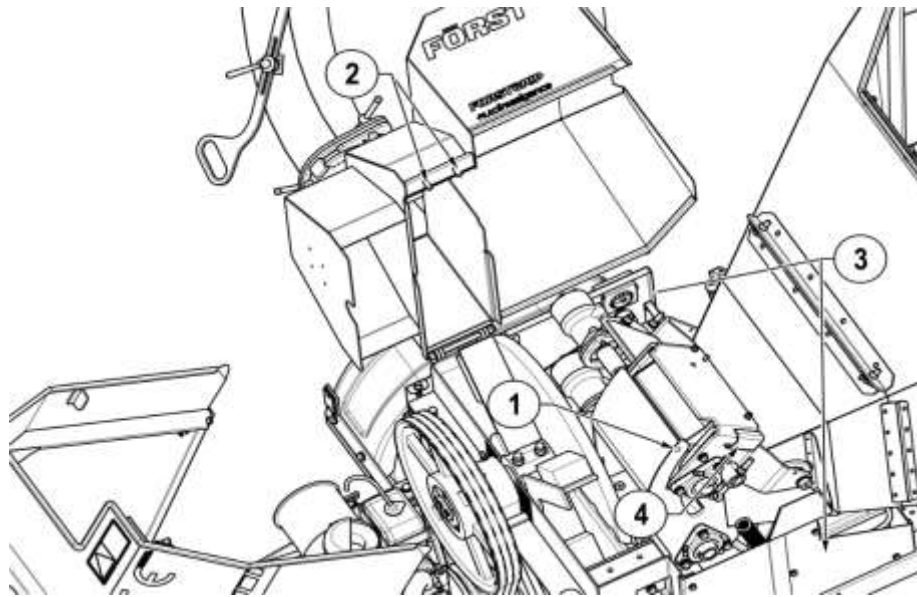

- | | |
|--|--|
| 1. Top feed roller M12 securing screw hole | 3. Side panels |
| 2. Chipping chamber cover fixing bolts | 4. Top feed roller lifting tool socket |

5.5.4 Engine Bay

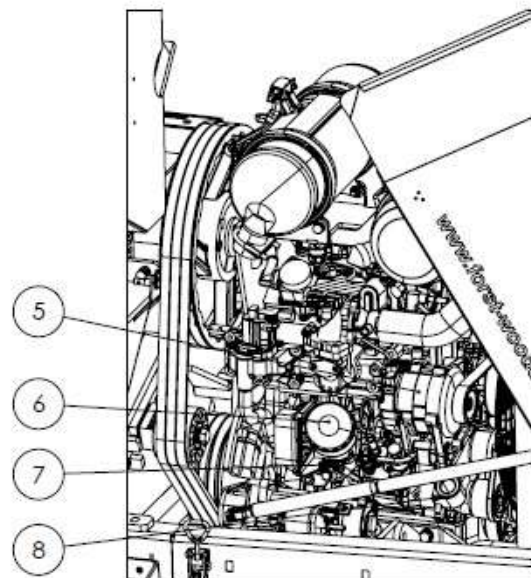
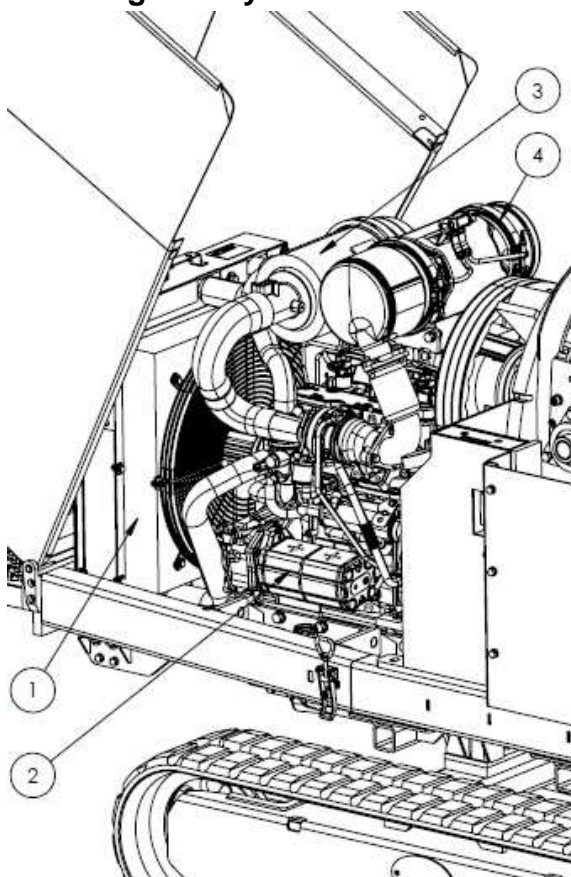

- | | |
|-------------------|-------------------|
| 1. Radiator | 5. Alternator |
| 2. Hydraulic Pump | 6. Oil filter |
| 3. Air cleaner | 7. Dipstick |
| 4. DPF | 8. Oil filler cap |

5.6 Blade Changing

WARNING – Rigger Gloves must be worn whilst changing the blades

WARNING – It is essential that only genuine parts are used guaranteeing the correct grade of Blade, bolt, washer and nut

1. Turn off chipper and remove the ignition keys
2. Disconnect battery leads
3. Remove the two bolts holding the chipping chamber lid closed (5.5.1)
4. Carefully open the chipping chamber lid from the chute side and let it come to rest on the hinge stops
5. Turn flywheel to blade change position and insert locking timber (pic 1)
6. Clean all debris from around the blade bolt and nut with a metal pick
7. With a 24mm socket undo the blade bolt nuts and remove bolts/nuts and washers steadying the blade with the other hand making sure it doesn't fall – WARNING these blades are sharp, rigger gloves must be worn
8. Carefully remove the blade from the flywheel
9. Clean blade seat on the flywheel thoroughly before fitting new or re-sharpened blades WARNING – the blades must not have any debris underneath them when tightened, the smallest amount of debris behind the blade could result in the blade coming loose causing damage to the machine
10. Re-fit blades, with new bolts, washers and nuts. Move the timber to the 2nd position (pic 2)
11. Shims may be required to keep the gap between the blade and the anvil on the inner edge (closest to the flywheel shaft) at 3mm
12. A calibrated torque wrench must be used to tighten the blade bolts to a torque setting of 310NM
13. Remove locking timber, rotate flywheel to next blade position and repeat 6-13
14. Close chipping chamber lid and re-fit bolts tightening to 86NM
15. Re-fit battery leads

WARNING – Failure to keep blades sharp will overload the engine and bearings which could result in machine breakdown.

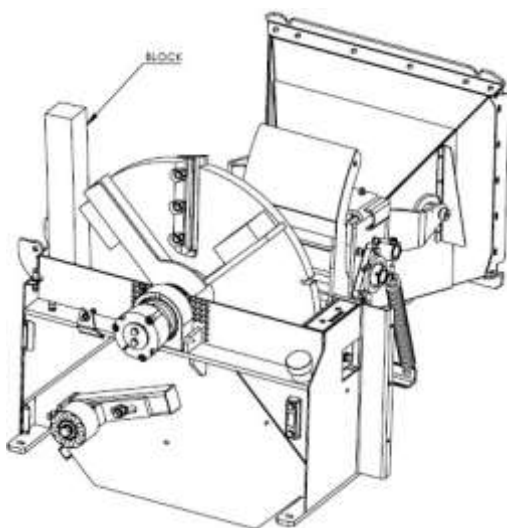

Pic 1

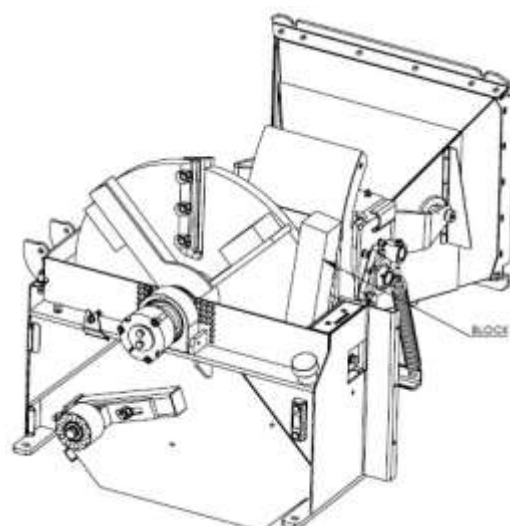

Pic 2

5.7 Blade Sharpening

For optimum performance, blades need to be kept sharp. Minimum safe blade size after sharpening is shown below. Also mark on the blade. After sharpening, the blade gap must be re-set by using a blade shim. Shims are available in thicknesses of 0.5, 1, 1.5, 2 & 2.5mm as part numbers 14-03-042-05, -10, -15, -20 and -25. On no occasion must more than one shim be fitted under each blade at any time. A gap of 3mm must be set from the inner blade tip to anvil after sharpening by placing an appropriate shim under the blade (also see flywheel assembly). The outer blade tip is automatically set due to the anvil being set at an angle to the blade. With 3mm at the inner blade tip, the outer blade tip should be 5mm from the anvil as shown below.

Blades must not be used beyond the wear mark. Failure to comply with this could result in damaging the machine, injury or loss of life.

The complete blade fastener set must be replaced every time blades are changed and torqued up to 310 Nm

DO NOT Lubricate the Bolts when fitting.

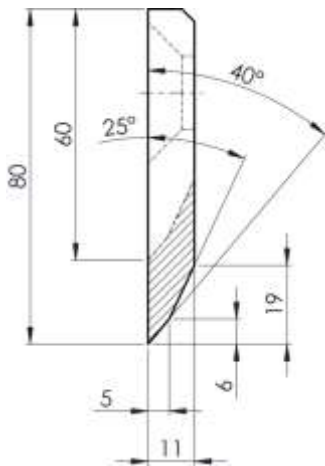

Blade sharpening limit
80mm to 60mm

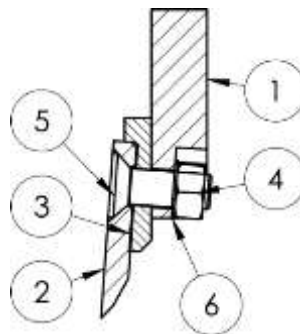

1. Flywheel
2. Flywheel blade
3. Blade shim
4. M16 x 10.9 hex nut
5. Blade bolt
6. M16 Serrated lock washer

1. Side Anvil
2. Anvil
3. Outside blade gap
4. Flywheel blade
5. Inside blade gap

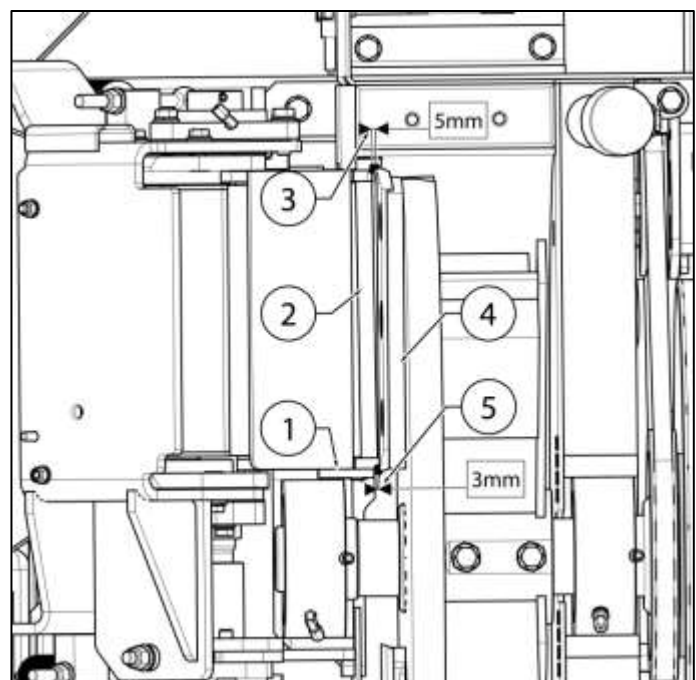

5.8 Hydraulic Oil Filter

Use protective plastic gloves to keep oil off skin, dispose of oil and filter in an environmentally responsible manner.

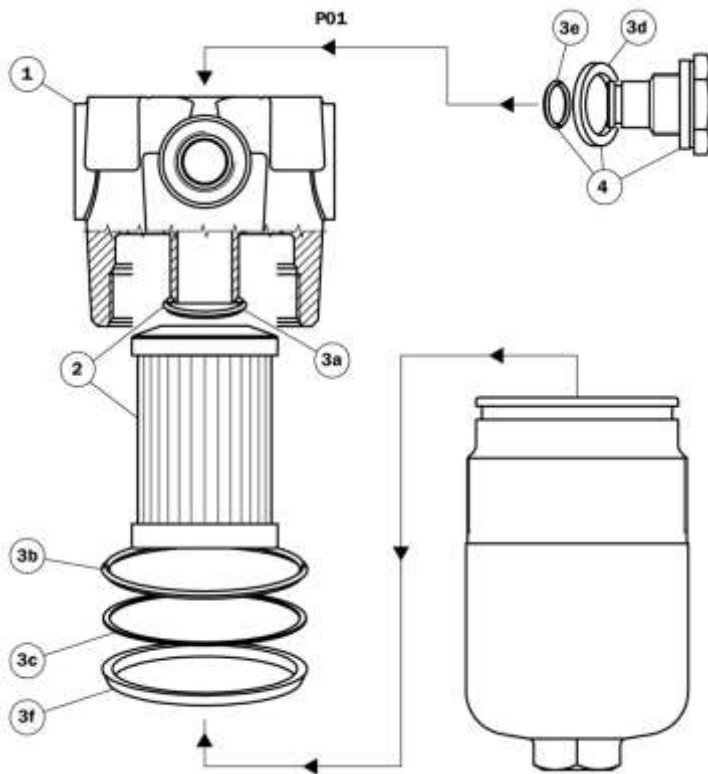

Item	Description	Qty
1	Complete Filter	1
2	Filter Element	1
3	Seal Kits	1
3a	O-ring for filter element	1
3b	O-ring for housing	1
3c	Anti-extrusion ring	1
3d	Gasket	1
3e	O-ring	1
3f	Protection seal	1
4	Indicator plug	1

5.6.1 Removal and Replacement

1. The filter housing is accessed via the left side panel. Clean around filler housing before removing to help prevent debris getting into oil.
2. Unscrew filter housing body, remove filter element and allow to drain for 15 minutes before disposal.
3. Screw on and tighten filter body with new filter into filter housing

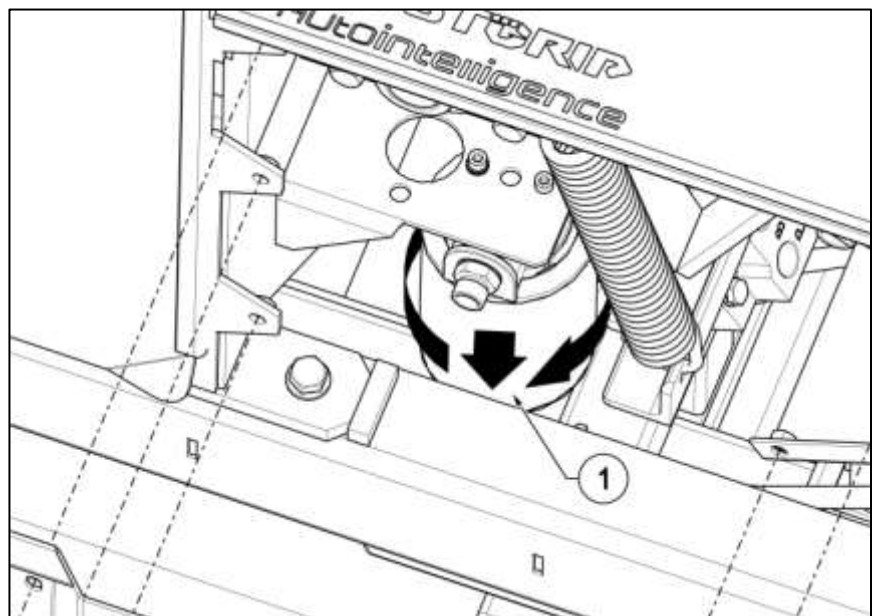

5.9 Oils, Fluids and Lubricants

Engine Oil: HD SAE 10w40 E9

Please consult your Doosan engine operator's manual for oil quantities relating to your engine type.

Hydraulic Oil: ISO VG 46.

It is advised that the oil is checked and topped up to the RED LINE on the sight glass, when the machine is cold and on a level surface.

Anti-Freeze: Mono-ethylene Glycol at a 50% mix ratio.

Please consult your Doosan engine operator's manual for coolant quantities relating to your engine type.

Grease: Lithium EP2 General Purpose. The greasing points can be found on the control panel. Please do not over grease 2 x pumps per grease nipple per week is sufficient.

5.10 Drive belt tension

The flywheel V belts must be checked for tension and condition. If any belt shows signs of wear, surface damage, shredding, excessive glazing, or have been stretched to their limit, they must be replaced. Multiple belt drives must have all belts replaced at the same time. Belts that are too slack will cause poor cutting performance, excessive belt and pulley wear.

All drive belts are located under the engine cover. Tension checked at arrow shown below. Check and set tension as follows:

1. Slacken clamp nut (6)
2. Turn adjuster nut (8) to tension belt until 4.5Kg force at the belt longest centre span deflects by 6mm. Can be approximated by firmly gripping belt between finger and thumb and twisting. The belt should not be able to be rotated more than 90°
3. Tighten all lock nuts
4. Run machine and test
5. Check belt tension

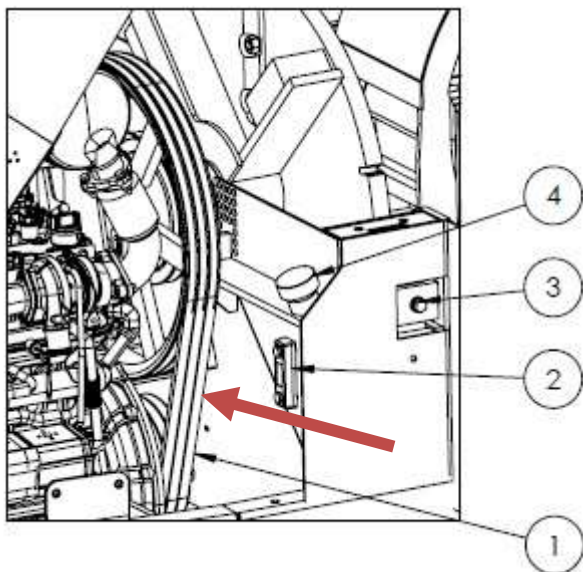

1. Flywheel drive belts
2. Hydraulic oil level gauge
3. Anvil clamp
4. Hydraulic oil filler cap

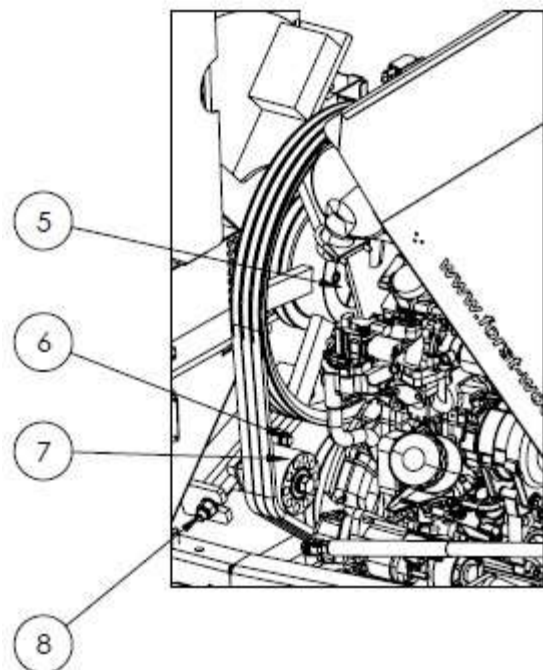

5. Flywheel retainer
6. Belt tensioner clamping nut
7. Idler pulley
8. Belt tensioner adjuster nut

5.11 Battery

5.11.1 Battery safety information

1. Battery acid is highly corrosive. For safety reasons, wear eye protection when handling a battery. Do not tilt battery as acid could escape from vents.
2. Keep children away from acid and batteries.
3. Battery emits highly explosive hydrogen gas when charged. Do not allow fires, sparks, naked flames or smoking near the battery. Also avoid electrostatic discharges and electrical sparks when dealing with cables and electrical equipment.
4. First aid. If acid is splashed into eyes, immediately rinse with clean water for several minutes and consult a doctor without delay. If acid is swallowed, consult a doctor immediately. Neutralise acid splashes on the skin and clothes immediately with acid neutraliser (a solution of water and soda/baking soda) or soap suds, and rinse with plenty of clean water.
5. Battery case can become brittle. To help avoid this, do not store batteries in direct sunlight. Discharged batteries could freeze so store in a frost-free area.
6. Dispose of old batteries at an authorised collection point. Never dispose of in household waste.

5.11.2 Storage and transport

1. As batteries are acid filled, always store and transport them upright and prevent from tilting to avoid acid escape.
2. Store in a cool, dry, frost free place.
3. Do not remove the protective positive terminal cap.
4. Run a First-in First-Out (FIFO) warehouse management system.

5.11.3 Initial operation

1. Batteries are filled with acid at a density of 1.28g/ml at 15°C during manufacture and are ready for use.
2. Recharge in case of insufficient starting power (see charging).

5.11.4 Battery removal & maintenance

To remove and replace battery:

1. Switch off engine and all electrical equipment.
2. To gain access to the battery, remove left side panel.
3. Avoid short circuiting the battery terminals and from positive to any metal machine part. Loose metal parts and tools commonly cause this.
4. Remove excessive debris from around the battery.
5. First remove negative lead at the battery, then the positive. Battery terminals are the take-off type and fastened with an M6 screw in to a ferrule on the cable end.
6. Slacken the M8 battery clamp screw.

7. Remove battery. Clean with a moist anti-static cloth to avoid electrostatic discharge and explosion risk. Charge and check electrolyte level if appropriate.
8. Clean out battery tray. Apply a thin film of petroleum jelly to terminals to prevent corrosion.
9. Replacement is the reversal of removal. Ensure to replace/fit any vent pipes. Leave at least one vent open otherwise there is an explosion risk. This also applies to old batteries removed for disposal/recycling. Swap new battery positive terminal protective cover to the old battery positive terminal to help prevent short circuits and sparks.

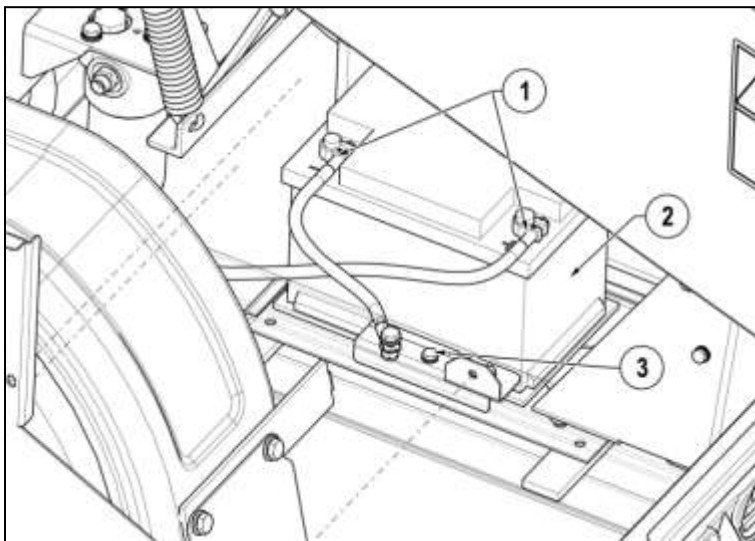

1. Take-off battery terminals fastened with M6 screw
2. Battery
3. Battery clamp M8

5.11.5 Charging

1. Remove battery from machine, disconnect negative terminal first.
2. Ensure good ventilation.
3. Use suitable direct current mains chargers only.
4. Connect battery positive terminal to charger output positive. Connect the negative terminal accordingly.
5. After connection, switch on charger. When charging is complete, switch off charger then disconnect battery.
6. Charging current recommendation is 10% of the battery Ah power rating.
7. Use a charger with a constant charging voltage of 14.4V.
8. If the acid temperature rises above 38°C, stop charging.
9. The battery is fully charged when the charging voltage or acid specific gravity has stopped rising for two hours.

5.11.6 Jump starting

1. Use a standardised jumper cable to DIN 72553 only and follow the instructions.
2. Only use batteries of the same voltage.
3. Switch off ignition on machine and support vehicle. The two must not touch and all lights/equipment must be turned off.

- Connect in the sequence of 1 – 2 – 3 – 4 as shown and as follows: Connect one end of the red jump lead to the machine battery positive (+) terminal.
4. Connect the other end of the red jump lead to the support vehicle battery positive (+) terminal.
 5. Connect one end of the black jump lead to the support vehicle battery negative (-) terminal.
 6. Connect other end of the black jump lead to a machine metal part away from the battery e.g. onto the engine from under the chassis.
 7. Make sure that the jump leads will not come into contact with moving parts.
 8. Start the support vehicle engine and run at a medium idle speed for 15 seconds.
 9. Start machine and run for 15 seconds.
 10. Disconnect jump leads in the reverse order 4 – 3 – 2 – 1.

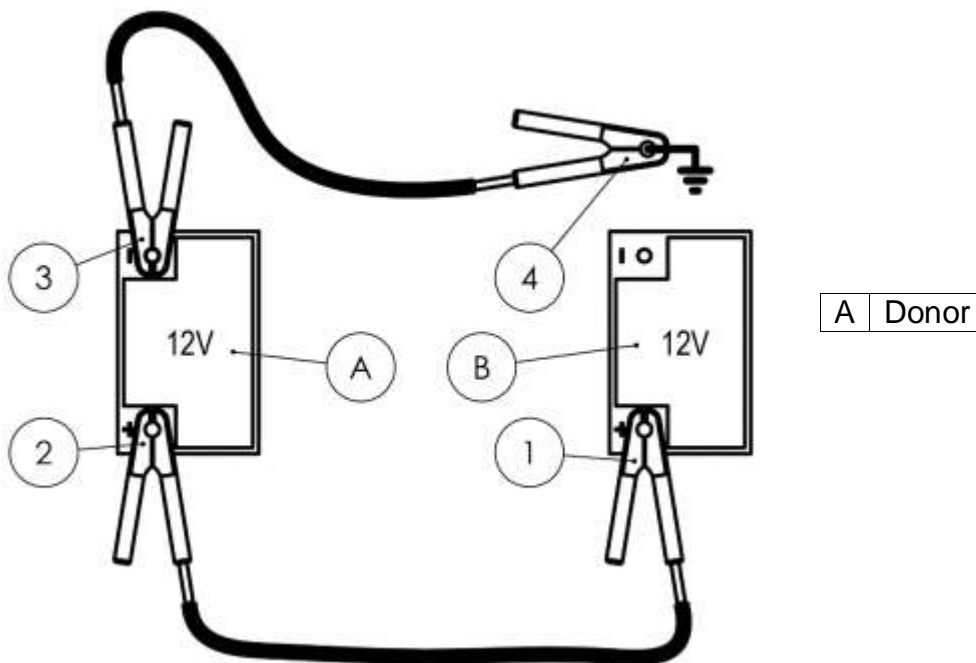

5.11.7 Taking battery out of service

1. Charge the battery and store in a cool but frost-free place or on the vehicle with the negative terminal disconnected.
2. Check the battery charge at regular intervals. Recharge if necessary.

6.0 Parts Lists & Diagrams

6.1 Tray & Stop Bar

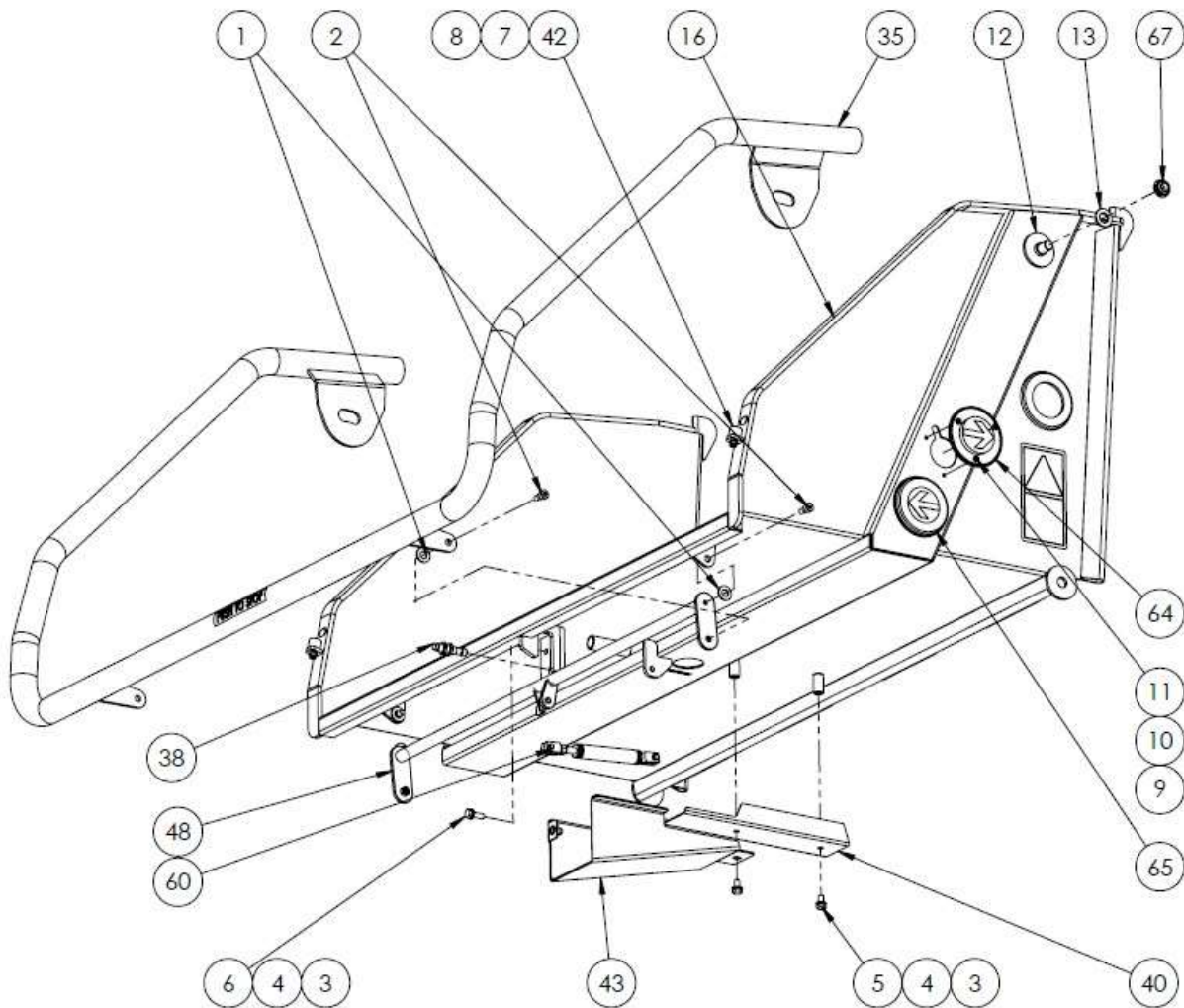

Item	Part No	Description	Qty
1	12-03-083	Cable cover	1
2	12-03-104	Trip mech guard fab Assy	1
3	12-05-050	Security Nut	2
4	12-10-071	Inductive proximity sensor kit	1
5	12-10-090	Buffer 15 x 20 M6	2
6	12-10-380	Captron Touch Sensor Assy - (Orange Reverse < Button)	2
7	12-10-383	Captron Touch Sensor Assy - (Green Forward > Button)	2
8	12-10-399	M8 x 8 Shoulder Bolt	4
9	12-12-101	M4 x 20 Pozi	12
10	12-12-401	M8 x 25 Lg 8.8 Hex Head screw	1
11	12-12-404	M8 x 16 Lg 8.8 Hex Head screw	2
12	12-13-015	M6 nyloc nut ISO 7040	2
13	12-14-002	M16 Nylon Washer extra large OD 56 x 5 THK ISO 7094	2
14	12-14-005	M16 Washer ISO 7089	2

Item	Part No	Description	Qty
15	12-14-013	M8 washer ISO 7089	3
16	12-14-014	M8 Spring washer DIN 128	3
17	12-14-017	M6 washer ISO 7089	2
18	12-14-020	M4 Washer	12
19	12-14-021	M4 Spring Washer	12
20	12-22-001	Loctite 222	1
21	12-26-002	Rotating machine parts	2
22	12-26-048	Push to stop	1
23	12-A-061	Stop Bar Spring	1
24	14-19-029	Sensor hopper tray fab Assy	1
25	14-19-090	8" Stop Bar - Hinged	1
26	14-19-091	8" Drive Bar	1
27	24-05-011	Stop Bar Collar	2
28	31-14-001	M12 Normal Nylon Washer	4

6.2 Chipping Chamber

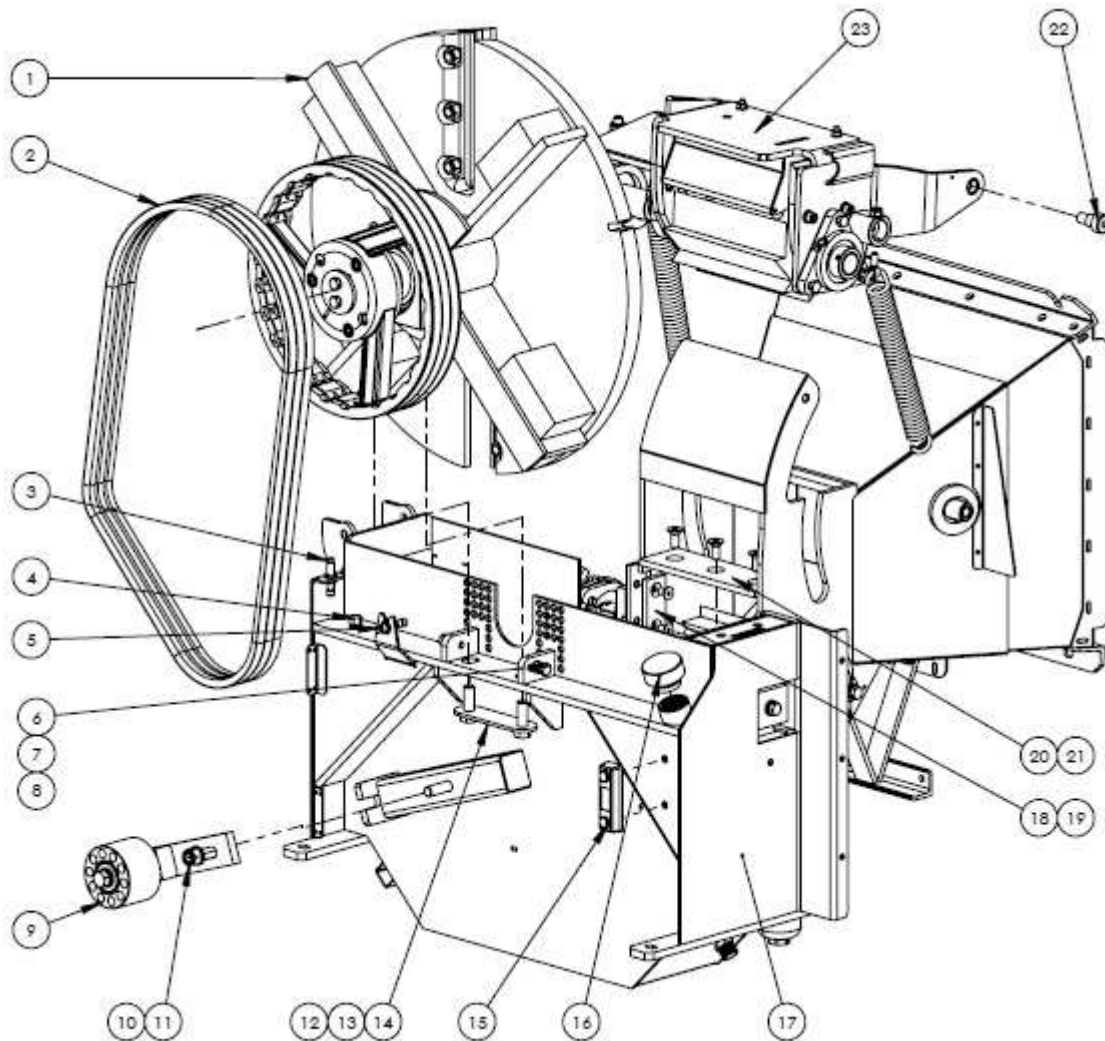

Item	Part No	Description	Qty
1	14-A-036	Flywheel Assy	1
2	12-10-305	B75 1940 Belt	3
3	12-10-071	Inductive proximity sensor kit	1
4	12-10-131	Brass vent screw 1/4in BSPP	1
5	12-10-071	Inductive proximity sensor kit	1
6	12-12-509	M10x35 Gr.8.8 Hex Bolt	2
7	12-13-006	M10 Plain Nut	2
8	12-99-008	M10 Serrated Washer	2
9	12-A-012	Flywheel belt tensioner assy	1
10	12-14-005	M16 Washer	1
11	12-13-005	M16 Nyloc	1
12	12-12-616	M16x45 Gr.10.9 Hex Bolt	4

Item	Part No	Description	Qty
13	12-14-006.1	M16 Serrated Washer	4
14	14-03-126	Washer Plate	1
15	12-24-003	Oil level glass	1
16	12-10-015	Hydraulic oil filler cap - plastic	1
17	18-19-015	ST8 50Hp Chipping Chamber	1
18	12-01-002	Side anvil	1
19	12-12-505	M10x20 Gr.10.9 CSK Screw	2
20	14-01-022	Anvil bed plate	1
21	12-12-610	M12x30 Gr.10.9 CSK Screw	3
22	12-01-008	M16x14 Should Bolt	2
23	14-A-008	Top feed roller assy	1

6.3 Top feed roller assembly

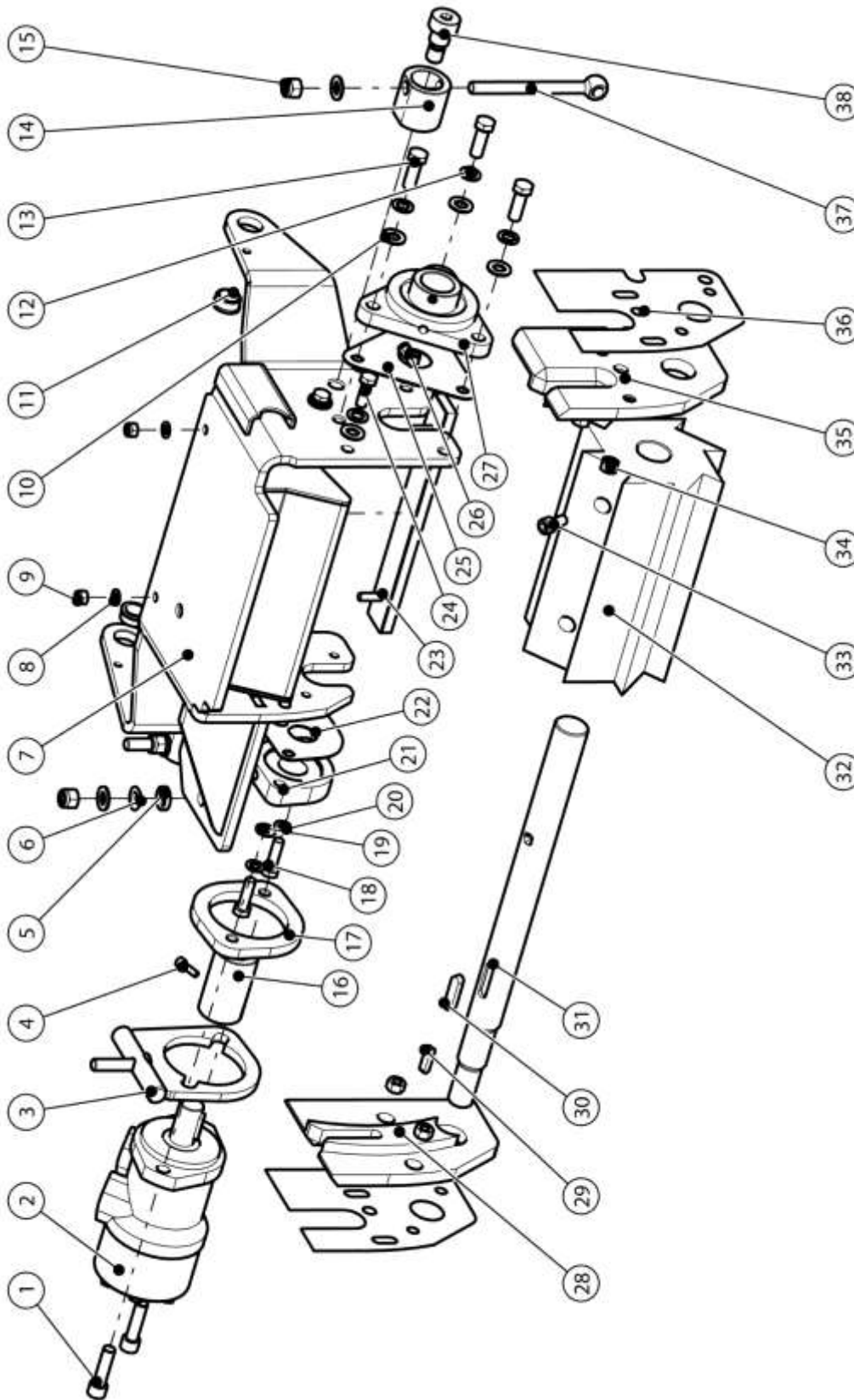

Item	Part No	Description	Qty
27	12-11-010	Self Aligning Flange Bearing 22.35 ID	1
28	14-01-027	Feed cheek RH 37mm slot	1
29	12-20-004	Rectangular key 30x8x7	1
30	12-20-005	Rectangular key 40x10x8	1
31	14-01-017	Top feed roller shaft	1
32	14-01-025	Top feed roller	1
33	12-01-044	M10 x 25Lg. 10.9 Cone Point Screw	1
34	12-13-006	M10 Hex nut	4
35	14-01-026	Feed cheek LH 37mm slot	1
36	14-03-061	Feed cheek shim 35 DIA shaft	2
37	12-12-613	M12 x 140 eyebolt DIN 444	2
38	12-01-008	Shoulder screw M16 x 14Lg	2

Item	Part No	Description	Qty
14	12-01-061	Feed adjuster collar	2
15	12-13-003	M12 nylon nut ISO 7040	3
16	12-01-049	Rigid shaft coupling 25 ID	1
17	12-19-133	Feed motor clamp	1
18	12-12-509	M10 x 35Lg 8.8 Hex Head screw	2
19	12-14-009	M10 Washer ISO 7089	2
20	12-14-010	M10 Spring Washer DIN 128	2
21	12-11-013	Self aligning flange bearing 2 hole 30 ID	1
22	12-03-102	Feed roller 2 hole bearing shim	1
23	14-02-001	Top Feed roller stop	1
24	12-12-502	M10 x 30Lg 8.8 Hex Head screw	4
25	14-03-041	Feed roller bearing shim 35 DIA	1
26	12-10-094	R1/8in BSPT 4mm male stud elbow	1

Item	Part No	Description	Qty
1	12-12-609	M12 x 45Lg 8.8 Socket Head Cap Screw	2
2	12-24-016	Hydraulic motor 250cc/rev	1
3	12-19-132	Feed motor bracket fab Assy	1
4	12-12-308	M5 x 20Lg Socket Head Cap Screw	4
5	12-10-127 Part D	M12 spherical dished washer	1
6	12-10-127 Part C	M12 spherical washer	1
7	14-19-020	Top feed housing fab Assy	1
8	12-14-013	M8 washer ISO 7089	2
9	12-13-011	M8 nylon nut ISO 7040	2
10	12-14-003	M12 Washer ISO 7089	10
11	12-11-004	Plain bearing 20 ID, 26 OD, 28 Flange x 12 Lg	2
12	12-14-015	M12 Spring washer DIN 128	7
13	12-12-608	M12 x 35Lg 8.8 Hex Head screw	3

6.4 Flywheel Assembly

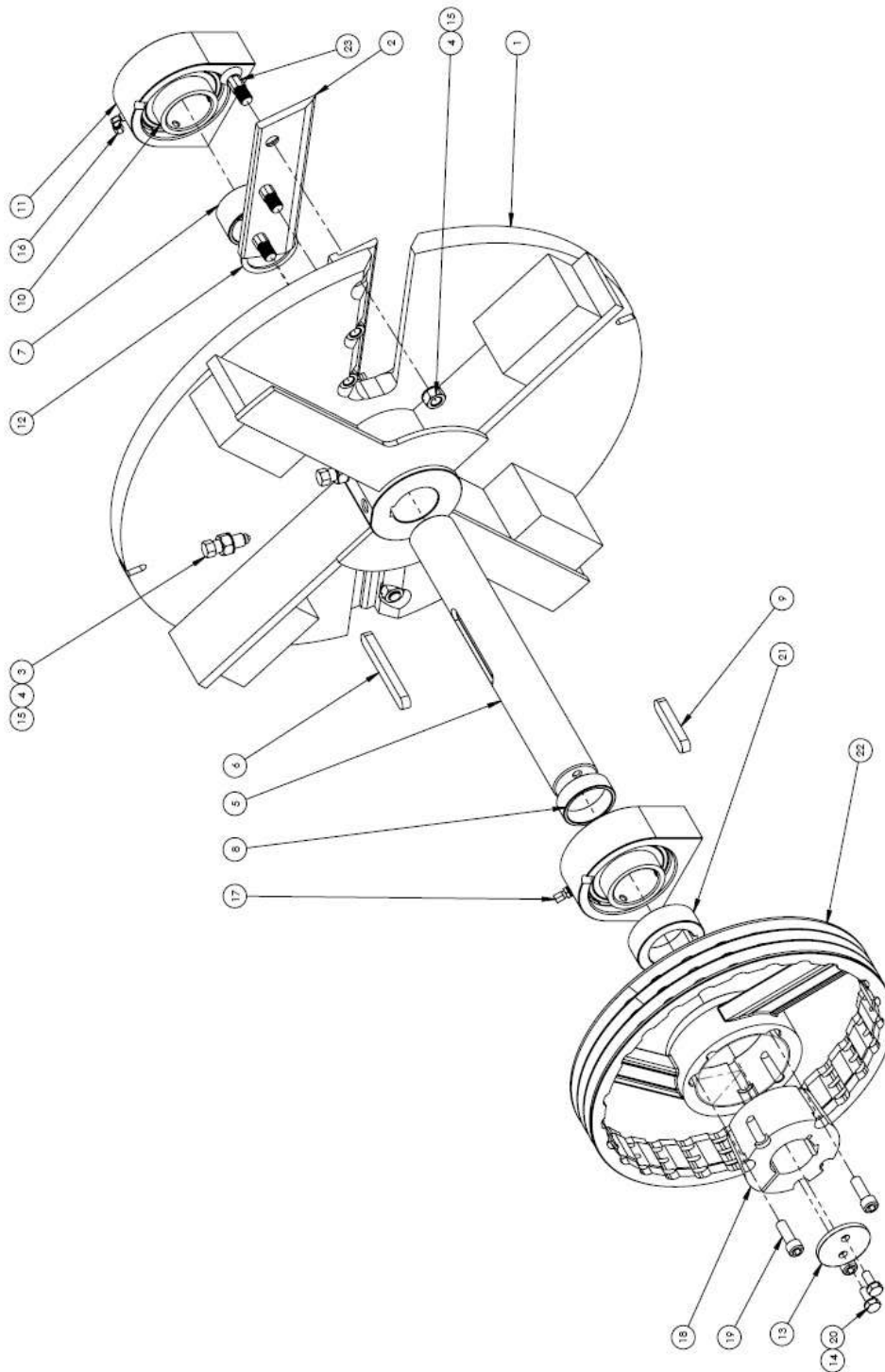

Item	Part No	Description	Qty
13	12-19-063	Pulley retainer	1
14	12-99-008	M10 Serrated Washer	2
15	12-14-006.1	M16 Serrated Washer	8
16	12-10-094	R1/Rin BSPT 4mm male stud elbow	1
17	12-10-075	G1/8in BSPP 4mm male stud coupling	1
18	12-10-123	3525 Tapelock x 60 Bone	1
19	10.5in x 1.5in	10.5in x 1.5in Gr.12.9 Socket Cap Head	3
20	12-12-506	M10x25 Gr.8.8 Hex Bolt	2
21	19-03-020	Flywheel Shaft spacer for X88	1
22	12-10-200	Cast 3 Bolt Flywheel Pulley 407mm	1
23	12-01-068	M16 Flywheel Blade Bolt	6

Item	Part No	Description	Qty
1	14-19-092	Square Flywheel Fabrication	1
2	14-01-003	Flywheel blade	2
3	12-12-1103	M16 x 50lg 8.8 Hex Head screw cone point	2
4	12-13-007	M16 Gr.10.9 Plain Nut	8
5	14-01-004	Flywheel shaft	1
6	12-20-008	Rectangular key 125x18x11	1
7	14-01-005	Flywheel shaft spacer	1
8	14-01-021	Flywheel shaft spacer	1
9	12-20-011	Rectangular key 85x18x11	1
10	14-01-029.1	Bearing 60 ID inner	2
11	14-01-029	Pillow block bearing 60 ID steel housing	2
12	12-10-124	Shim .75 OD x .60 ID x .3 THK	1

6.5 Bottom Feed Roller

Item No	Part No	Description	Quantity
1	12-20-004	Rectangular key 30x8x7	1
2	12-12-509	M10 x 35Lg 8.8 Hex Head screw	2
3	12-12-308	M5 x 20Lg Socket Head Cap Screw	4
4	12-19-132	Feed motor bracket fab assy	1
5	12-24-005	Hydraulic motor 199.6cc/rev	1
6	12-12-609	M12 x 45Lg 8.8 Socket Head Cap Screw	2
7	12-10-127 Part D	M12 spherical dished washer	1
8	12-10-127 Part C	M12 spherical washer	1
9	12-14-003	M12 Washer ISO 7089	1
10	12-13-003	M12 nyloc nut ISO 7040	1
11	12-19-133	Feed motor clamp	1
12	12-01-049	Rigid shaft coupling 25 ID	1
13	12-14-010	M10 Spring Washer DIN 128	2
14	12-14-009	M10 Washer ISO 7089	2
15	12-01-062	Feed bearing clamp	1
16	12-01-052	Oilite 30 ID spherical bearing	1
17	12-20-005	Rectangular key 40x10x8	1
18	12-01-053	Feed roller spherical bearing housing	1
19	14-01-018	Bottom feed roller shaft	1
20	14-01-016	Feed roller	1
21	12-01-044	M10 x 25Lg 10.9 Cone Point Screw	1

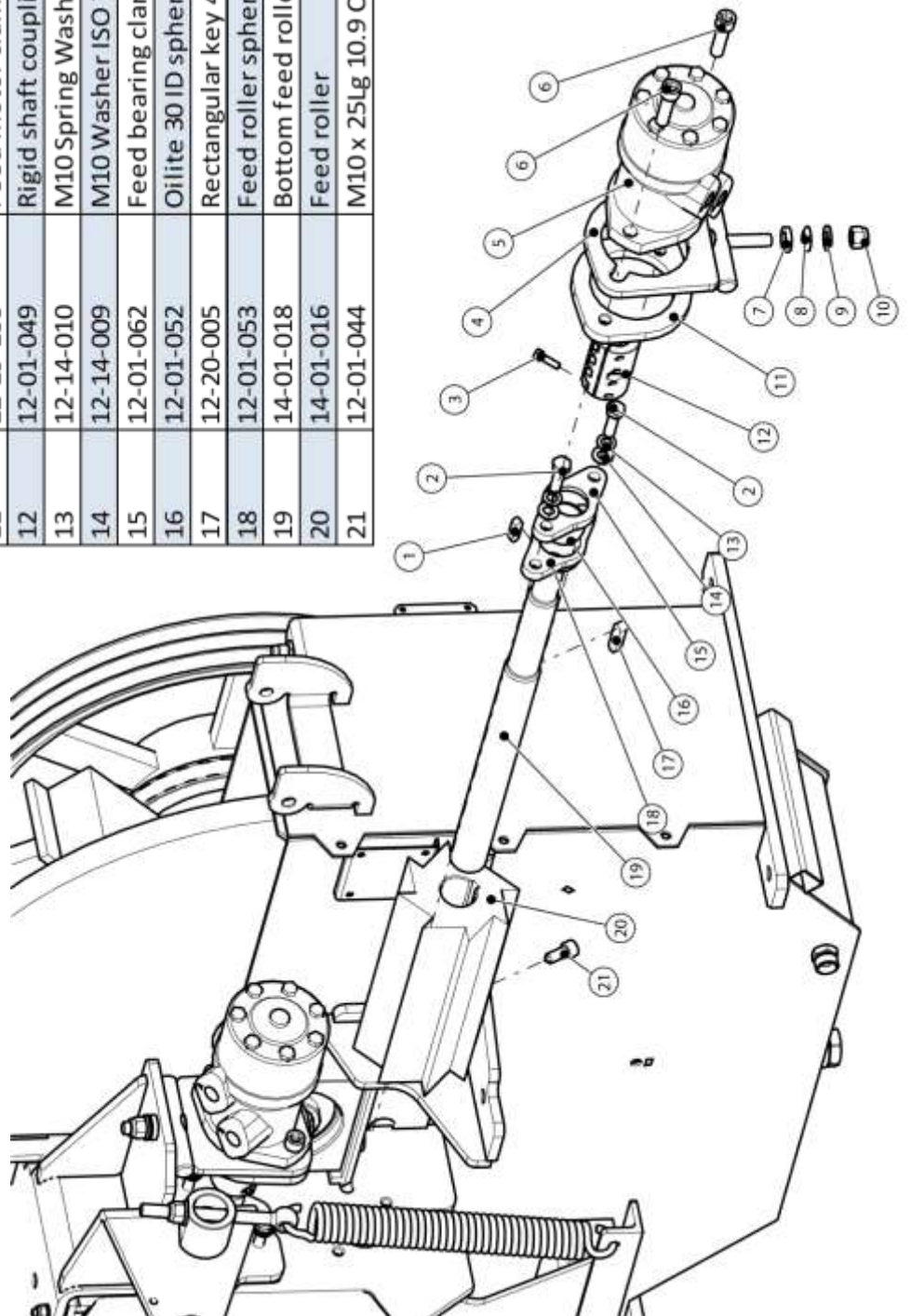

6.6 Anvil

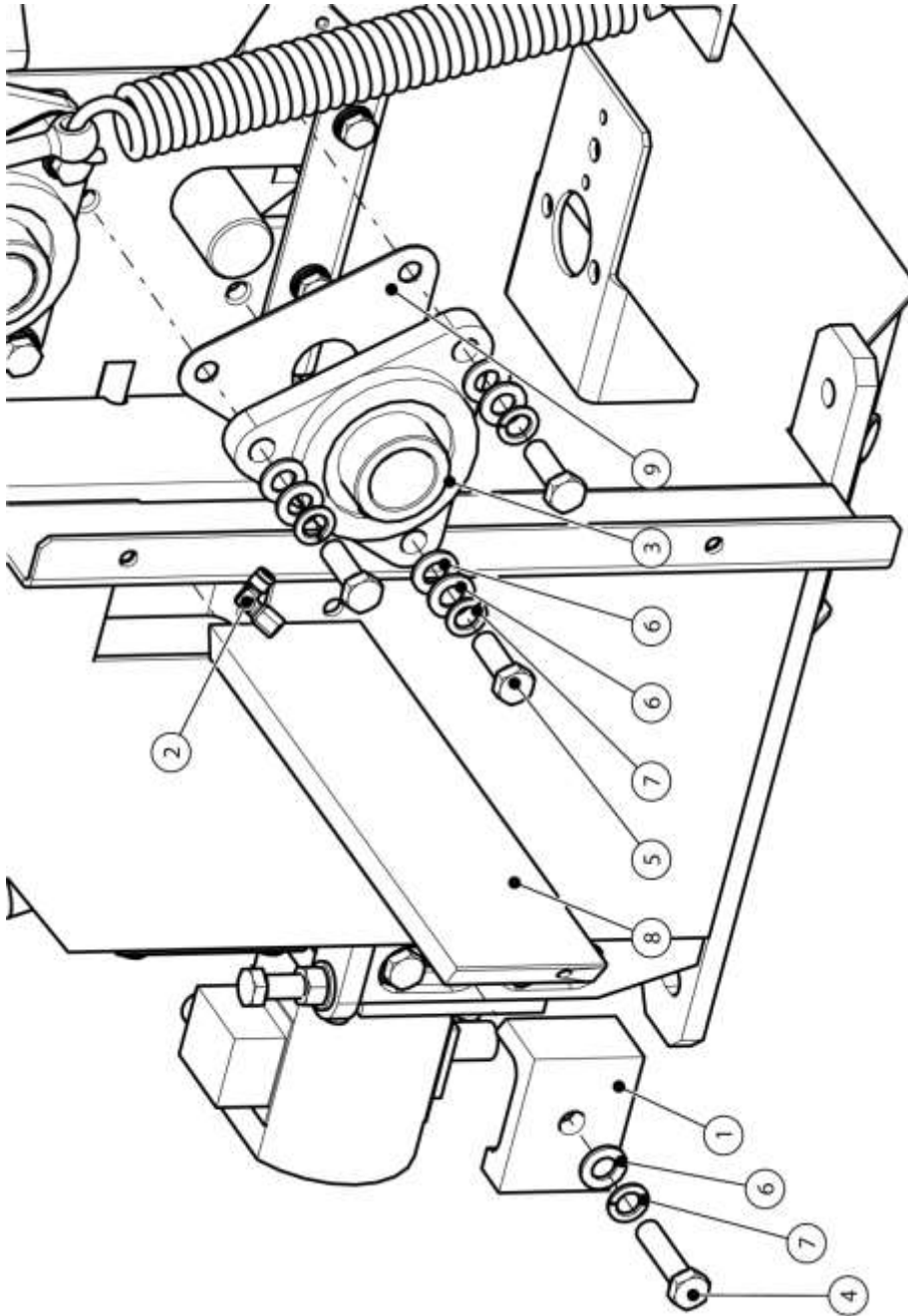

Item No	Part No	Description	Quantity
1	12-01-003	Anvil clamp	1
2	12-10-094	R1/8in BSPT 4mm male stud elbow	1
3	12-11-010	Self Aligning Flange Bearing 22 35 ID	1
4	12-12-601	M12 x 50Lg 8.8 Hex Head screw	1
5	12-12-608	M12 x 35Lg 8.8 Hex Head screw	3
6	12-14-003	M12 Washer ISO 7089	7
7	12-14-015	M12 Spring washer DIN 128	4
8	14-01-014	Anvil	1
9	14-03-041	Feed roller bearing shim 35 DIA	1

6.7 Stone Trap

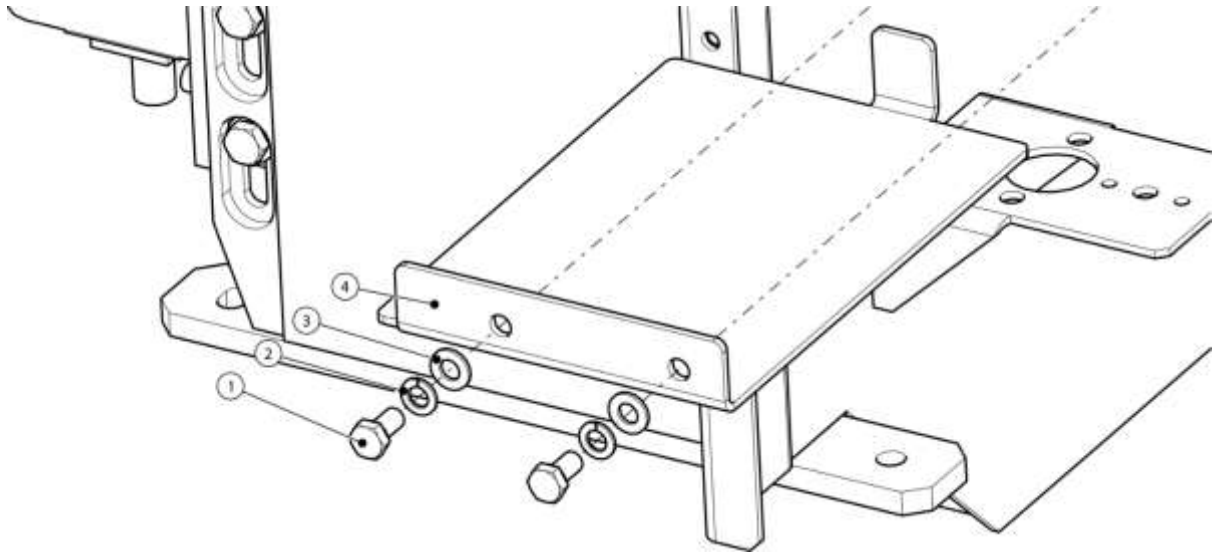

Item No	Part No	Description	Quantity
1	12-12-504	M10 x 20Lg 8.8 Hex Head screw	2
2	12-14-010	M10 Spring Washer DIN 128	2
3	12-14-009	M10 Washer ISO 7089	2
4	14-03-024	Feed roller cover	1

6.8 Flywheel belt tensioner assembly

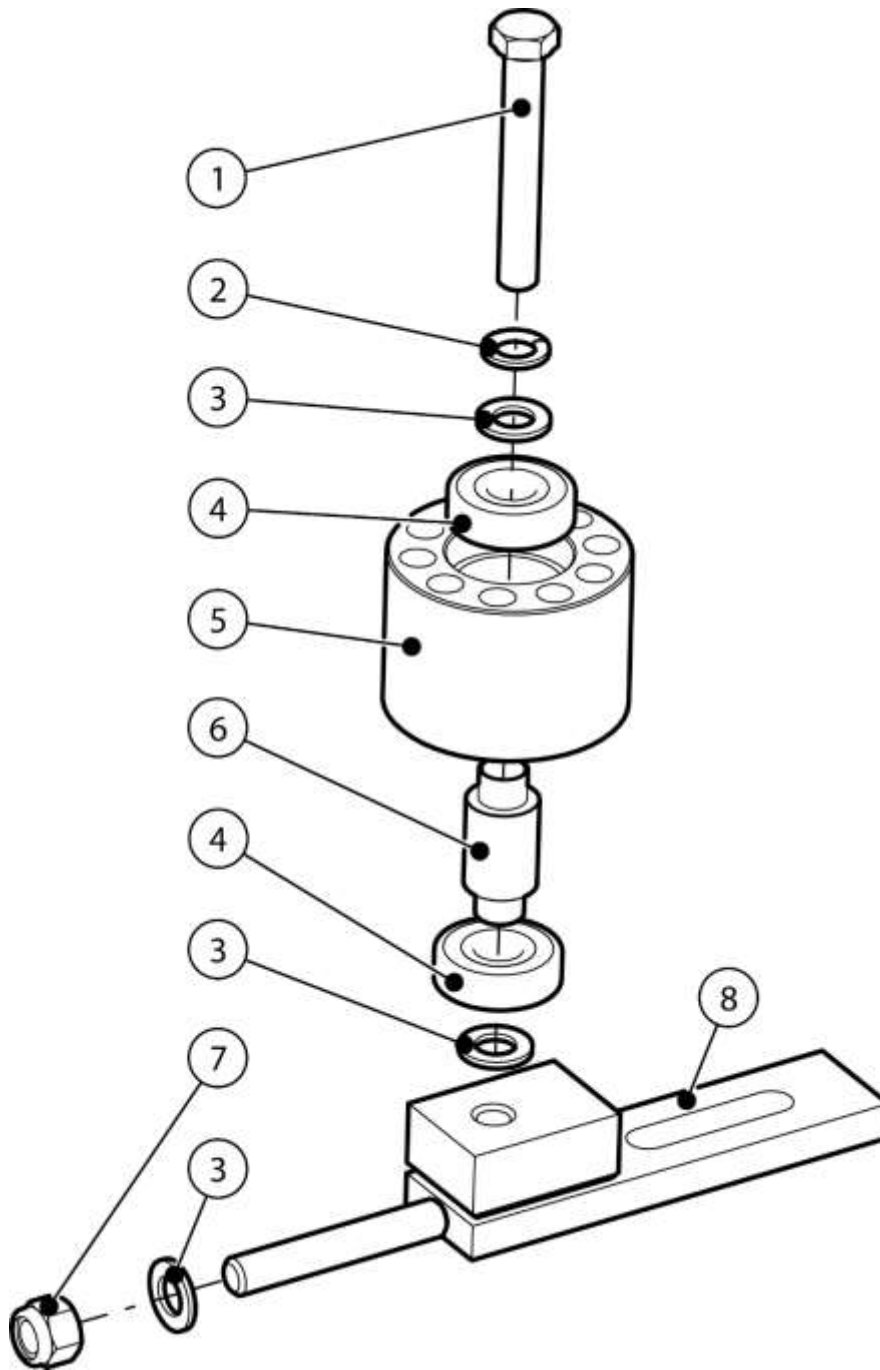

Item No	Part No	Description	Quantity
1	12-12-1104	M16 x 110Lg 8.8 Hex Head bolt	1
2	12-14-019	M16 Spring washer DIN 128	1
3	12-14-005	M16 Washer ISO 7089	3
4	12-11-011	6304 2RS Deep groove ball bearing 52 OD, 20 ID, 15 wide	2
5	12-01-036	Flat idler pulley-2x 17 V belt	1
6	12-01-024	Flat idler pulley shaft-2x 17 V belt	1
7	12-13-005	M16 nyloc nut ISO 7040	1
8	14-19-019	Tensioner slide fab assy	1

6.9 Safety Curtain

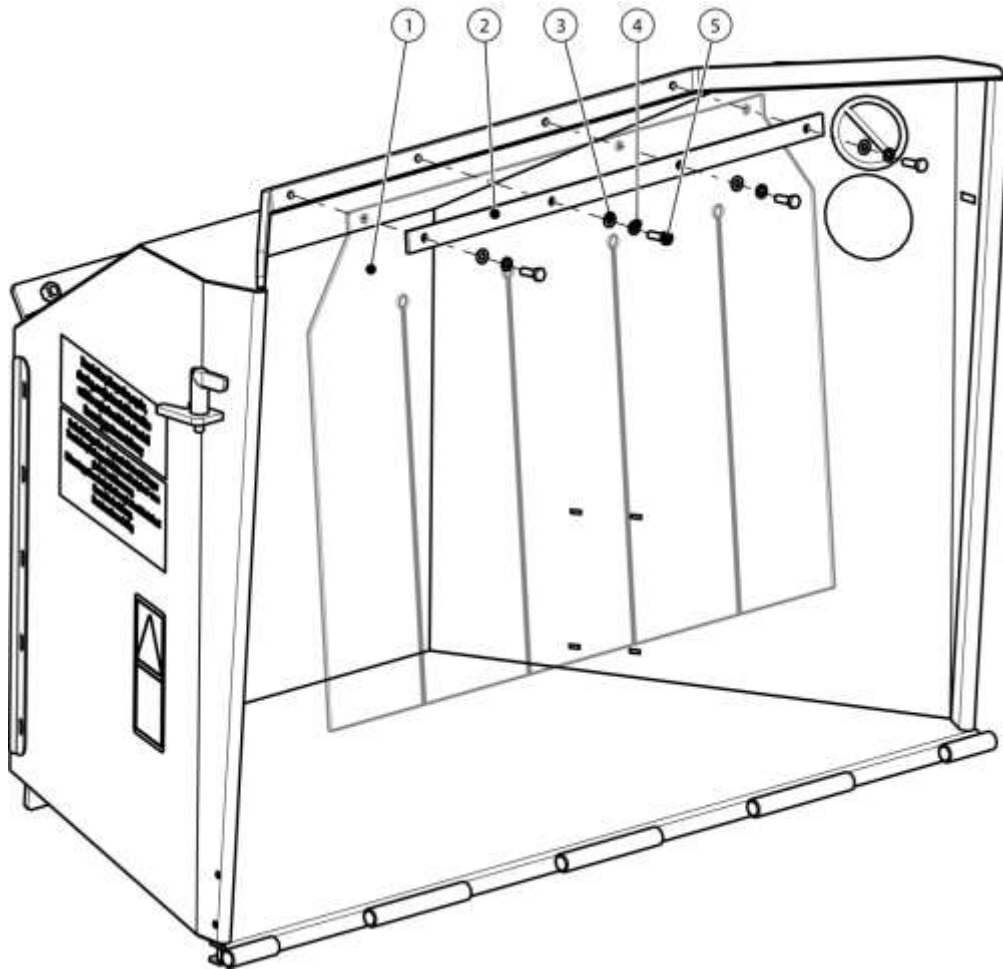

Item No	Part No	Description	Quantity
1	14-05-008	Safety curtain	1
2	14-05-007	Curtain clamp	1
3	12-14-013	M8 washer ISO 7089	4
4	12-14-014	M8 Spring washer DIN 128	4
5	12-12-401	M8 x 25 Lg 8.8 Hex Head screw	4

6.10 Chute Assembly

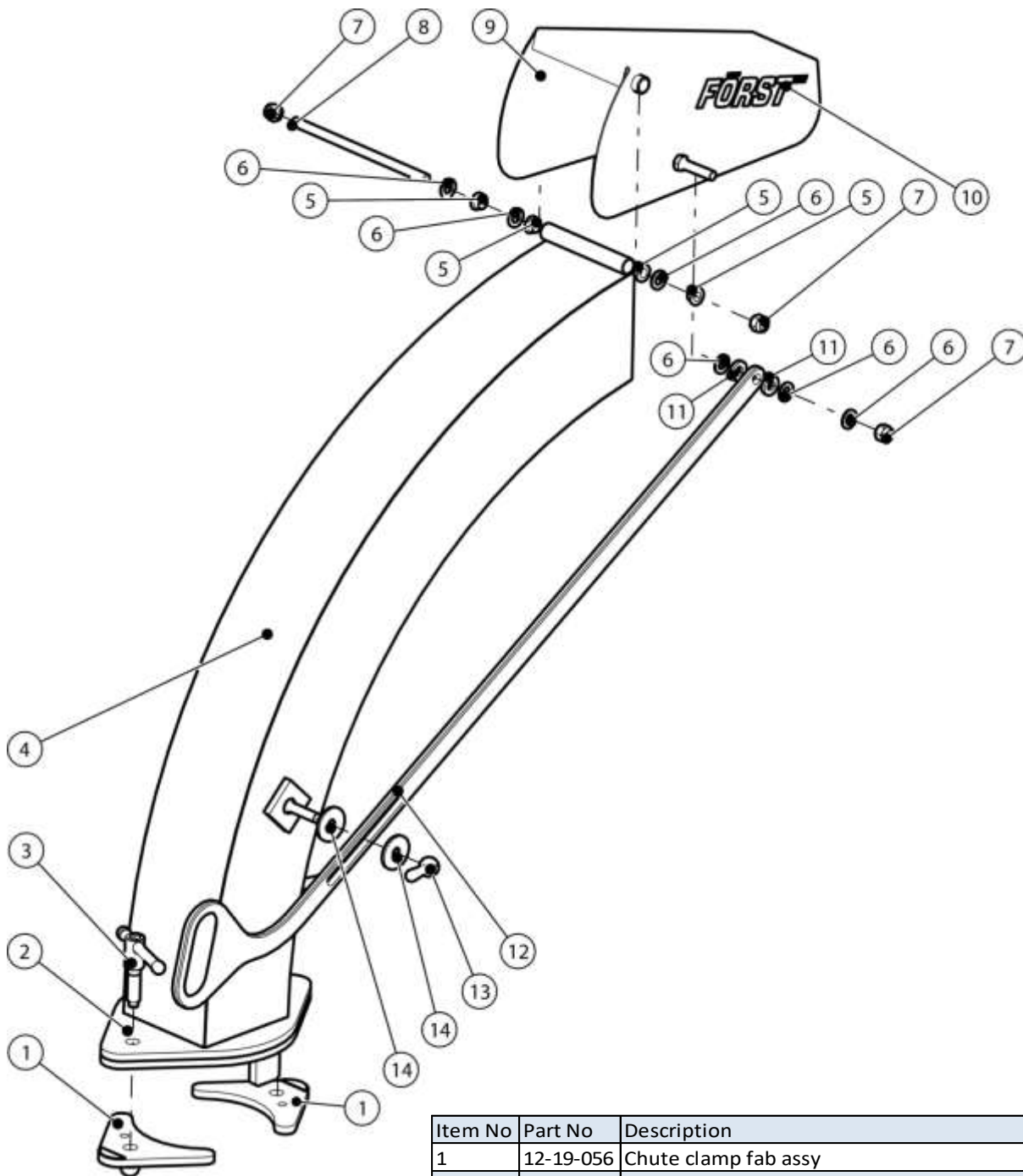

Item No	Part No	Description	Quantity
1	12-19-056	Chute clamp fab assy	2
2	12-20-001	Spring Pin Slotted 10 DIA x 30Lg ISO 8752	2
3	12-10-005	M16 T bar screw	2
4	12-19-051	Chute fab assy	1
5	12-11-007	Plain bearing 12 ID, 16 OD, 22 flange x 10 Lg	4
6	12-14-003	M12 Washer ISO 7089	6
7	12-13-003	M12 nyloc nut ISO 7040	3
8	12-01-043	Hood hinge stud	1
9	12-19-051	Chute hood fab assy	1
10	12-30-024	Forst small orange decal	2
11	12-15-020	M12 Elastomer washer OD 25-ID 12 x 5 THK	2
12	12-19-055	Chute handle - standard	1
13	12-10-004	M12 female steel handle	1
14	12-14-004	M12 Washer extra large OD 44 x 4 THK ISO 7094	2

6.11 Fuel tank assembly

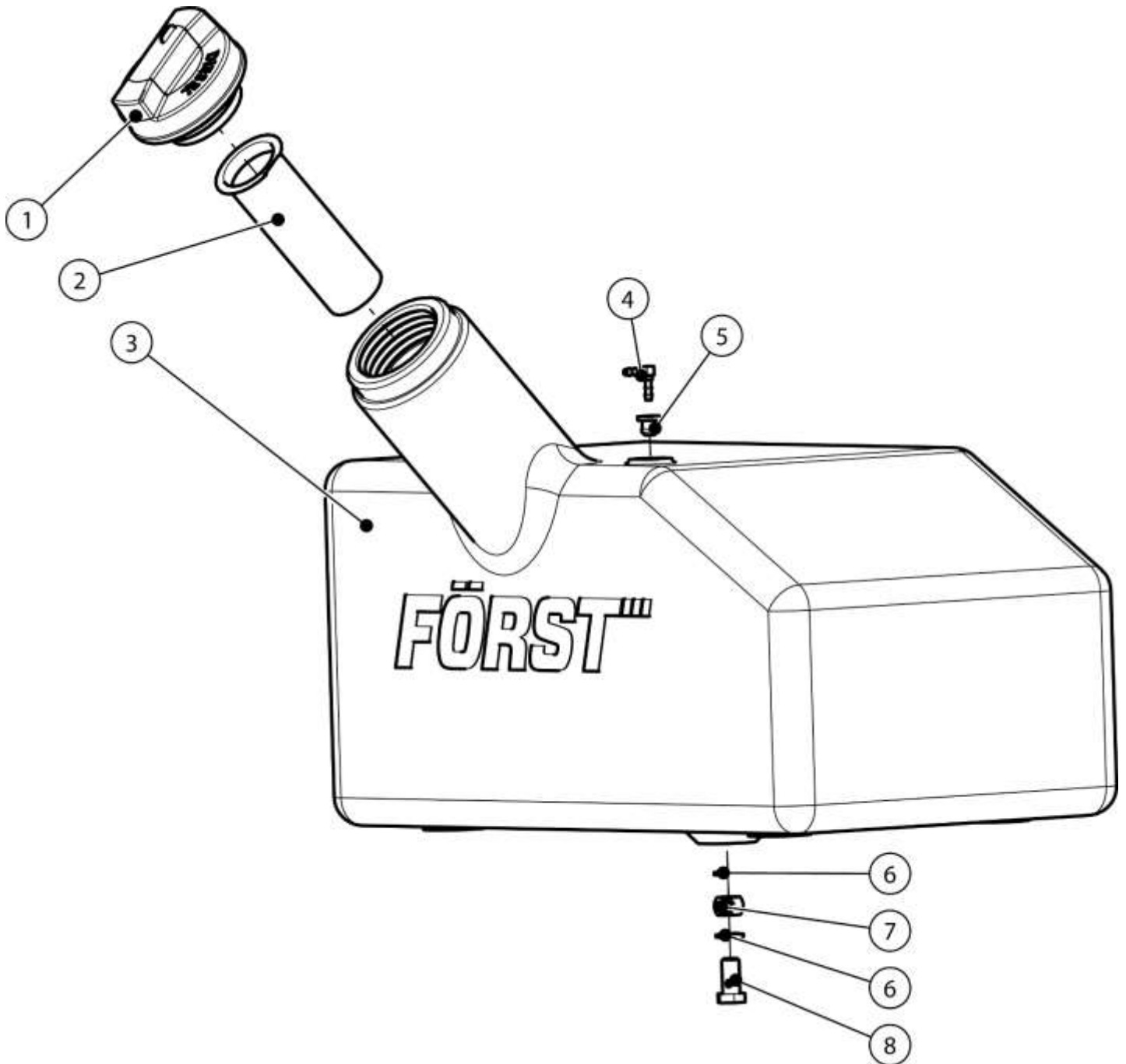

Item No	Part No	Description	Quantity
1	12-10-150	Fuel tank cap	1
1a	12-10-151	Lockable fuel cap (optional)	1
2	12-10-152	Fuel tank filter	1
3	12-02-001	Fuel tank 35L moulded assy	1
4	12-10-154	Fuel tank 5mm connector	1
5	12-10-153	Fuel tank 5mm grommet	1
6	12-14-008	M12 Bonded washer (Dowty)	2
7	12-10-027	Banjo M12	1
8	12-10-026	Banjo bolt M12	1

6.12 Hydraulics circuit diagram

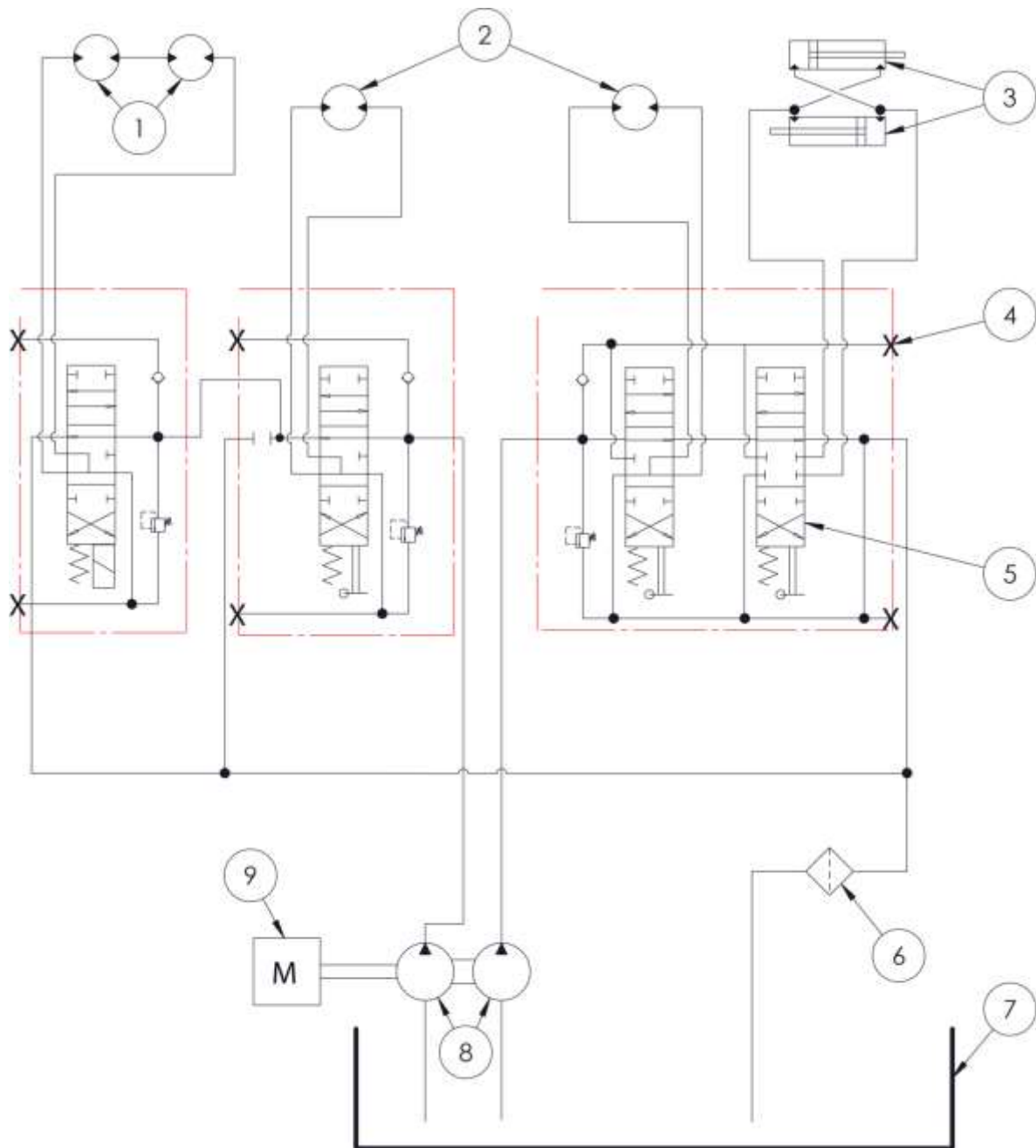

- | | |
|--|--------------------------------------|
| 1. Feed roller motors | 5. Control valve |
| 2. Track motors | 6. Return Line Filter |
| 3. Track width cylinders
(optional) | 7. Oil tank |
| 4. Test points | 8. Tandem hydraulic
pump 11cc/rev |
| | 9. Engine |

6.13 Electrical Circuit Diagrams

6.13.1 Touch Sensors

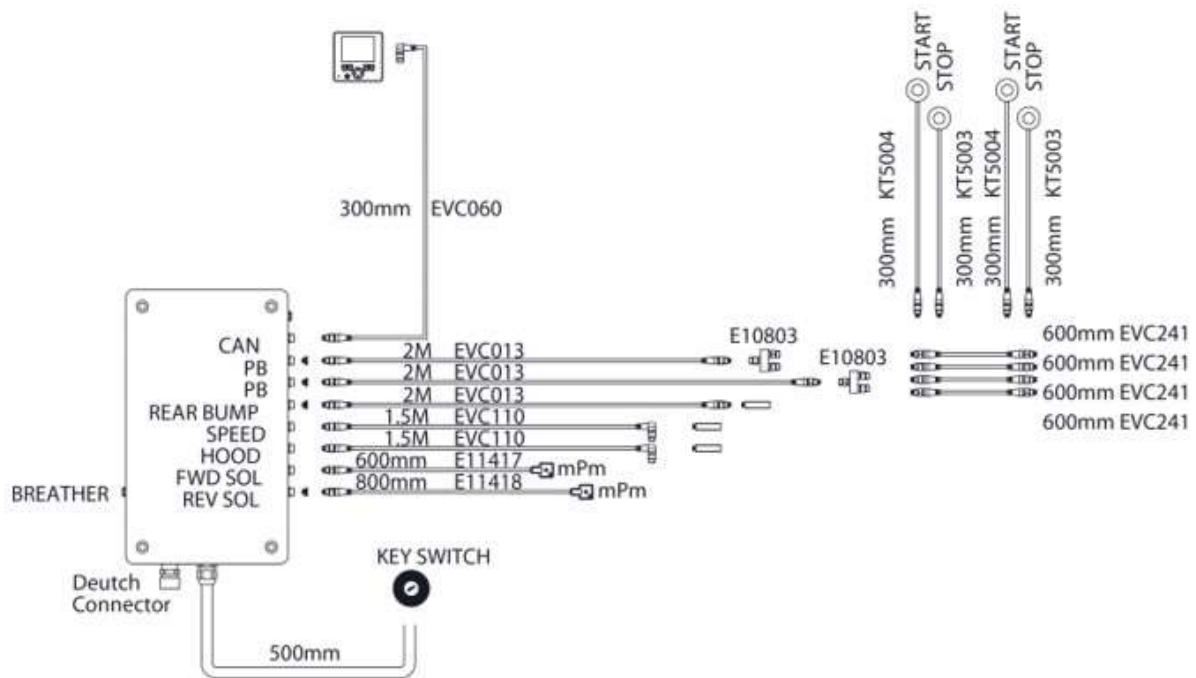

6.13.2 Wiring Harness

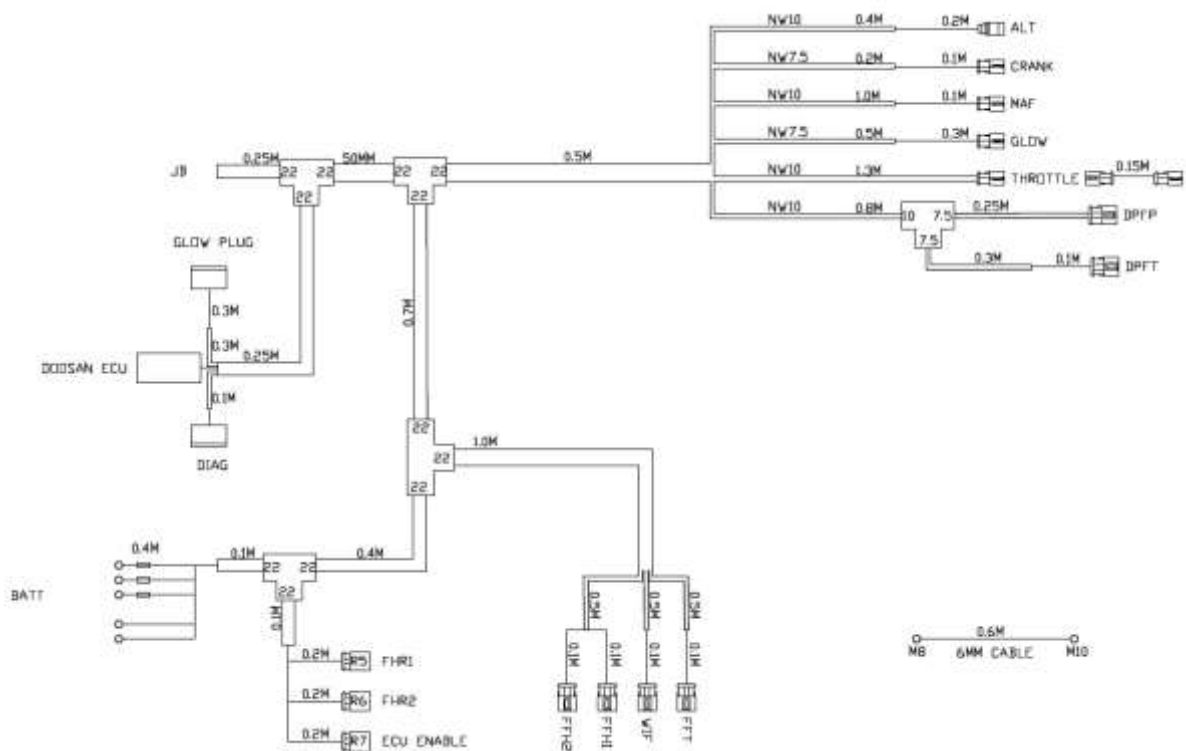

6.14 Decals

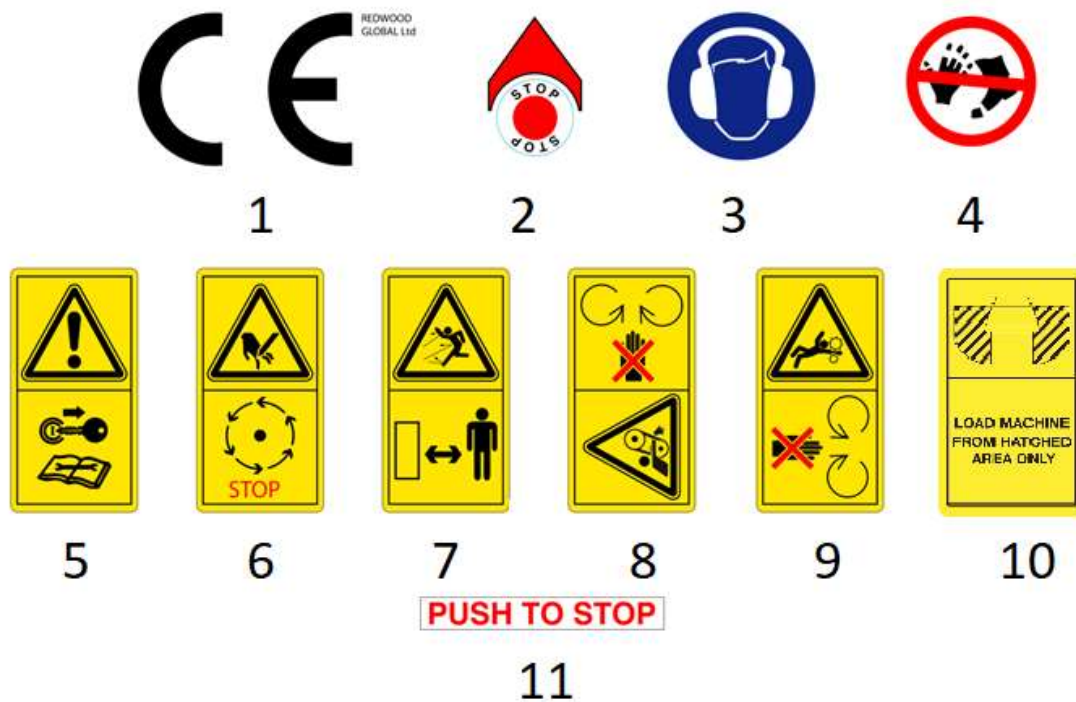

Decal meaning:

1. CE (Conformité Européenne or European Conformity) mark. Manufacturer's declaration that the product complies with the essential requirements of the relevant European health, safety and environment protection legislation
2. Ignition switch stop
3. Hearing and eye protection of an appropriate specification to be worn
4. Finger and toe amputation hazard
5. Refer to user manual
6. Allow machine to stop before touching
7. Danger from flying objects
8. Do not open or remove covers while engine is running
9. Keep away from rotating machine parts
10. Load the machine only from the sides of the hopper
11. Push to stop, trip bar operation

These decals are placed on the machine where the hazard or information applies.

6.15 Manufacturer's Statutory Plate



Information on the Manufacturer's plate in line order from top to bottom is as follows:

1. Manufacturing company & address
2. Serial Number
3. Machine designation
4. Mass
5. Power of prime mover
6. Year of construction
7. Sound Power Level
8. Drive rotation
9. Website & CE Mark

7.0 Warranty and Certification

7.1 Warranty

7.1.1 Warranty Statement

1. Redwood Global Ltd guarantee all Först equipment supplied by them against any defect in manufacture and assembly – this guarantee is for a period of 12 months commencing on the date of sale to the first end user.
2. The guarantee will not apply to a failure where normal use has exhausted the life of a component.
3. Engine units are covered independently by their respective manufacturer's warranties.
4. Redwood Global Ltd's liability under this guarantee is limited to repair at Redwood Global Ltd's premises or at a selected Först dealer.
5. No liability will be accepted for consequential lost or damage of any kind.
6. The Redwood Global Ltd guarantee is restricted to the first Redwood Global Ltd user only and is not transferable except when authorized by Redwood Global Ltd.
7. The owner is responsible to make sure the chipper is operated at all times in accordance with the user manual.
8. The Redwood Global Ltd guarantee will be invalidated if any of the following points apply:
 - Failure to use genuine Först parts
 - Failure to perform routine servicing and maintenance
 - Failed parts or assembly have been interfered with
 - Chipper has been modified without written approval from Redwood Global Ltd
 - Chipper has been used to performed tasks contrary to those stated in the Redwood Global Ltd User Manual
 - Exclusions to the above warranty terms are – fair wear and tear on fuses and bulbs, tyres and brakes, lubrications and filters, blades and anvils, feed rollers and paintwork.
 - Where an extended warranty has been given this will be stated on the original chipper invoice and will be subject to further conditions as stated in our supplementary warranty terms

7.1.2 Warranty Claims

To obtain warranty service please contact Redwood Global Ltd for the nearest approved Först Dealer. Your nearest dealer can be obtained from Redwood Global Ltd at the address on the front of the User Manual. In the event of a failure Redwood Global Ltd must be notified within 7 working days.

7.2 Certification



**CERTIFICATE & DECLARATION OF CONFORMITY
FOR CE MARKING**

Company contact details:

Redwood Global Ltd,
Unit 86, Livingstone Road, Walworth Business Park, Andover,
Hampshire. SP10 5NS. United Kingdom

Redwood Global Ltd declares that their:

Wood Chippers listed as the following models

TT6 Towed

ST6 Towed & TR6 on Tracks

ST8 Towed & TR8 on Tracks

XR8 on Tracks

are classified within the following EU Directives:

Machinery Directive 2006/42/EC

Electromagnetic Compatibility Directive 2004/108/EC

and further conform with the following EU Harmonized Standards:

EN13525:2005 + A2:2009

EN 982:1996+A1:2008

EN ISO 12100:2010

EN ISO 14982:2009

Dated:

Position of signatory: Managing Partner

Name of Signatory: Raymond Gardner

Signed below:

.....

on behalf of Redwood Global Ltd